

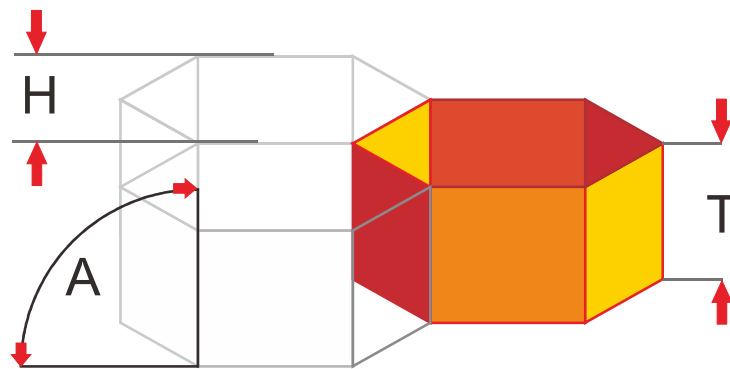

BICYCLE  
 COMPOSITE OEM/OEM/OEM  
 • 2014 •



RTM/VRTM  
 (Resin Transfer Moulding)



HOSE BLOW METHOD



HIGH PRESSURE  
 & METAL WITH  
 LOT PIECES



SPECIAL MATERIAL  
 AND EQUIPMENT  
 TOOL APPLICATION



HIGH TEMPERATURE



CARBON CNC



HONEYCOMB CORE



## ROS 106 MONOCOQUE COMPACT 一体成型

**MATERIAL:** 100% CARBON  
材质

**FINISH:** UD,6A,3A,12D,3K,8F  
外观

**SIZE:** 440,480,520,560MM  
尺寸

**BIG HEAD TUBE:** UPPER ID42MM  
大头管: 上端内径 LOWER ID52MM  
下端内径

**HEAD TUBE SET:** FSA:NO.42ACB  
头管腕组: 天心

**SMALL HEAD TUBE:**  
小头管: 上端内径  
下端内径

**HEAD TUBE SET:**  
头管腕组: 天心

**SEAT TUBE SIZE:** ID31.8MM  
座管尺寸: 内径

**SEAT POST SIZE:** T008 / OD31.6MM  
座管柱尺寸: 外径

**SEAT POST CLAMP:** CS13/CS16  
座管束

**BB:** FSA BB30  
五通

**WEIGHT:** (WITH NO SEAT POST, WITH NO  
重量 COSMETICS) 1045±20G (520MM)

**AVAILABLE FRONT FORK:** RF24  
配置前叉

**HEAD TUBE STIFFNESS:** 100 Nm/0  
头管刚性

**BB STIFFNESS:** 130 Nm/0  
五通刚性

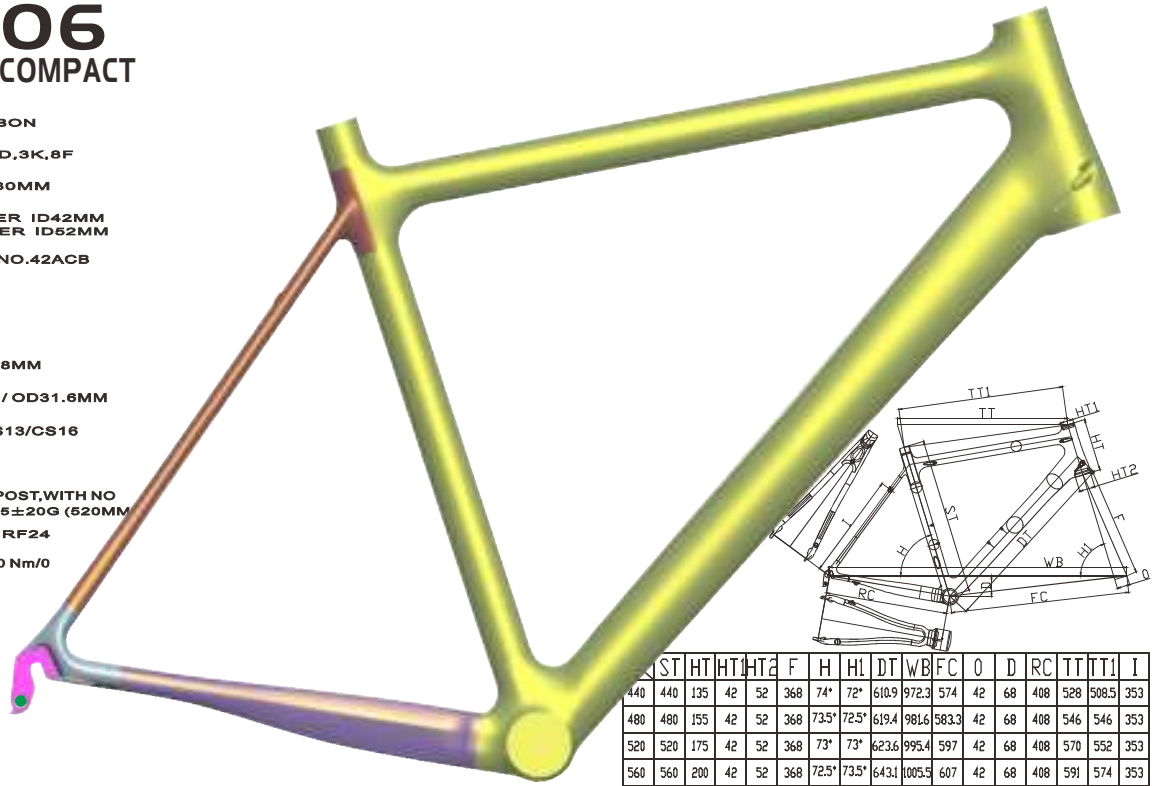

| ST  | HT  | HT1 | HT2 | F  | H   | HL    | DT    | WB    | FC     | O     | D  | RC | TT  | TT1 | I     |     |
|-----|-----|-----|-----|----|-----|-------|-------|-------|--------|-------|----|----|-----|-----|-------|-----|
| 440 | 440 | 135 | 42  | 52 | 368 | 74°   | 72°   | 610.9 | 972.3  | 574   | 42 | 68 | 408 | 528 | 508.5 | 353 |
| 480 | 480 | 135 | 42  | 52 | 368 | 73.5° | 72.5° | 619.4 | 981.6  | 583.3 | 42 | 68 | 408 | 546 | 546   | 353 |
| 520 | 520 | 175 | 42  | 52 | 368 | 73°   | 73°   | 623.6 | 995.4  | 597   | 42 | 68 | 408 | 570 | 552   | 353 |
| 560 | 560 | 200 | 42  | 52 | 368 | 72.5° | 73.5° | 643.1 | 1005.5 | 607   | 42 | 68 | 408 | 591 | 574   | 353 |

## ROT 60 MONOCOQUE COMPACT 一体成型

**MATERIAL:** 100% CARBON  
材质

**FINISH:** UD,6A,3A,12D,3K,8F  
外观

**SIZE:** 480,500,520,540,560,580,600,620MM  
尺寸

**BIG HEAD TUBE:** UPPER ID42MM  
大头管: 上端内径 LOWER ID52MM  
下端内径

**HEAD TUBE SET:** FSA:NO.42ACB  
头管腕组: 天心

**SMALL HEAD TUBE:**  
小头管: 上端内径  
下端内径

**HEAD TUBE SET:**  
头管腕组: 天心

**SEAT TUBE SIZE:** ID31.8MM  
座管尺寸: 内径

**SEAT POST SIZE:** T008 / OD31.6MM  
座管柱尺寸: 外径

**SEAT POST CLAMP:** CS13/CS16  
座管束

**BB:** FSA BB30  
五通

**WEIGHT:** (WITH NO SEAT POST, WITH NO  
重量 COSMETICS) 1100±20G (620MM)

**AVAILABLE FRONT FORK:** RF52  
配置前叉

**HEAD TUBE STIFFNESS:** 110 Nm/0  
头管刚性

**BB STIFFNESS:** 145 Nm/0  
五通刚性



| ST  | A   | B  | C      | D  | E     | F   | G      | H      | I     | J     | HT  | RC  | FC    |
|-----|-----|----|--------|----|-------|-----|--------|--------|-------|-------|-----|-----|-------|
| 480 | 372 | 39 | 71.25* | 70 | 74.8* | 520 | φ42/47 | φ52/56 | φ34.9 | φ31.8 | 105 | 410 | 576.1 |
| 500 | 372 | 39 | 71.25* | 70 | 74.3* | 525 | φ42/47 | φ52/56 | φ34.9 | φ31.8 | 110 | 410 | 576.6 |
| 520 | 372 | 39 | 72*    | 70 | 74*   | 537 | φ42/47 | φ52/56 | φ34.9 | φ31.8 | 115 | 405 | 579.3 |
| 540 | 372 | 39 | 72.5*  | 70 | 74*   | 543 | φ42/47 | φ52/56 | φ34.9 | φ31.8 | 135 | 405 | 580.6 |
| 560 | 372 | 39 | 73.5*  | 70 | 73.5* | 555 | φ42/47 | φ52/56 | φ34.9 | φ31.8 | 150 | 405 | 579.2 |
| 580 | 372 | 39 | 73.5*  | 70 | 73.5* | 570 | φ42/47 | φ52/56 | φ34.9 | φ31.8 | 180 | 405 | 594.1 |
| 600 | 372 | 39 | 73.5*  | 70 | 73.5* | 582 | φ42/47 | φ52/56 | φ34.9 | φ31.8 | 190 | 405 | 606   |
| 620 | 372 | 39 | 73.5*  | 70 | 73*   | 588 | φ42/47 | φ52/56 | φ34.9 | φ31.8 | 210 | 405 | 606.1 |

## ROS-70

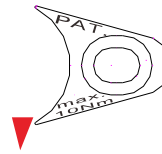

CS15

REVOLUTION!! SEAT TUBE COMPE  
IMPLEMENT. WITHOUT THE SEAT  
POST CLAMP REDUCES THE  
RESIST FROM THE WIND.

## ROS-69

PAT.

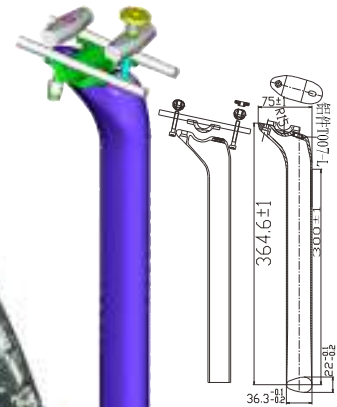

**T007**

MATERIAL: 100% Carbon  
WEIGHT: 110 ± 5 g  
SCREW: M5 X 30mm : 1PCS  
M5 X 35mm : 1PCS

## ROS 33 MONOCOQUE COMPACT 一体成型

MATERIAL: 100% CARBON

材质

FINISH: UD,6A,3A,12D,3K,8F

外观

SIZE: 470,500,520,540,560,590MM

尺寸

BIG HEAD TUBE: A:UPPER ID42MM

大头管: 上端内径

LOWER ID62MM

下端内径

HEAD TUBE SET: FSA:NO.42ACB

头管腕组: 天心

SMALL HEAD TUBE: B:UPPER ID41.7MM

小头管: 上端内径

LOWER ID41.7MM

下端内径

HEAD TUBE SET: FSA:NO.8

头管腕组: 天心

SEAT TUBE SIZE: ID31.8MM

座管尺寸: 内径

SEAT POST SIZE: T008 / OD31.6MM

座管柱尺寸: 外径

SEAT POST CLAMP: CS13/CS16

座管束

BB: FSA BB30

五通

WEIGHT: (WITH NO SEAT POST,WITH NO

重量 COSMETICS) 1273±20G (520MM)

AVAILABLE FRONT FORK: A:RF24

配置前叉

B:RF01,RF03,

RF04,RF06,

RF10-S,RF11

RF21-S

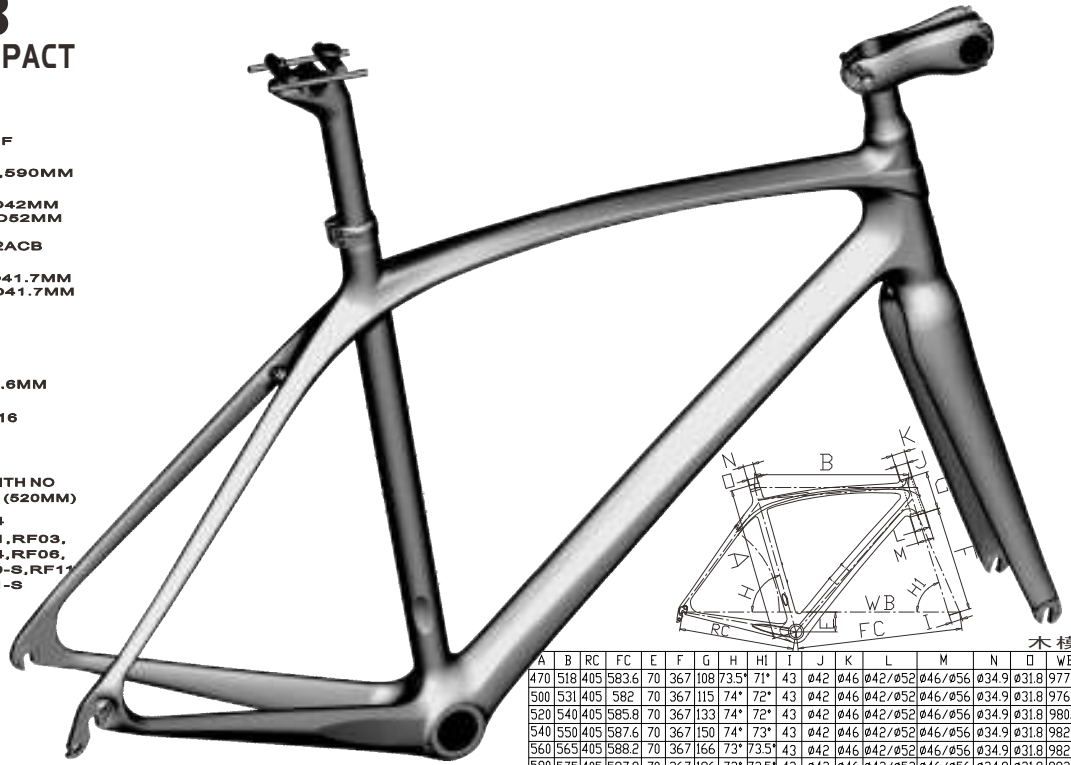

| A   | B   | RC  | FC    | E  | F   | G   | H     | HI    | I  | J   | K   | L       | M       | N     | O     | WB    |
|-----|-----|-----|-------|----|-----|-----|-------|-------|----|-----|-----|---------|---------|-------|-------|-------|
| 470 | 518 | 405 | 583.6 | 70 | 367 | 108 | 73.5* | 71*   | 43 | 042 | 046 | 042/052 | 046/056 | 034.9 | 031.8 | 977.5 |
| 500 | 531 | 405 | 582   | 70 | 367 | 115 | 74*   | 72*   | 43 | 042 | 046 | 042/052 | 046/056 | 034.9 | 031.8 | 976.7 |
| 520 | 540 | 405 | 585.8 | 70 | 367 | 133 | 74*   | 72*   | 43 | 042 | 046 | 042/052 | 046/056 | 034.9 | 031.8 | 980.5 |
| 540 | 550 | 405 | 587.6 | 70 | 367 | 150 | 74*   | 73*   | 43 | 042 | 046 | 042/052 | 046/056 | 034.9 | 031.8 | 982.3 |
| 560 | 565 | 405 | 588.2 | 70 | 367 | 166 | 73*   | 73.5* | 43 | 042 | 046 | 042/052 | 046/056 | 034.9 | 031.8 | 982.9 |
| 590 | 575 | 405 | 597.9 | 70 | 367 | 196 | 73*   | 73.5* | 43 | 042 | 046 | 042/052 | 046/056 | 034.9 | 031.8 | 992.7 |

木模

## ROT-57-68



**ROS-12**  
**ROSP-12**  
 PAT.

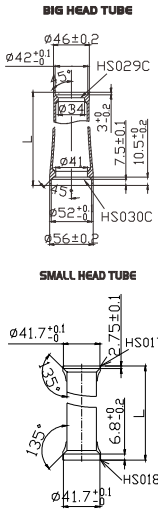

**ROS-08**



RLT-07



RLS-04



## ROT-05



## ROS 02B MONOCOQUE COMPACT

一体成型

MATERIAL: 100% CARBON

材质

FINISH: UD,6A,3A,12D,3K,8F

外观

SIZE: 440,580,520,560MM

尺寸

BIG HEAD TUBE: A:UPPER ID42MM  
大头管: 上端内径 LOWER ID52MM  
下端内径

HEAD TUBE SET: FSA:NO.42ACB

头管碗组: 天心

SMALL HEAD TUBE: B:UPPER ID41.7MM  
小头管: 上端内径 LOWER ID41.7MM  
下端内径

HEAD TUBE SET: FSA:NO.8

头管碗组: 天心

SEAT TUBE SIZE: ID31.8MM

座管尺寸: 内径

SEAT POST SIZE: T008 / OD31.6MM

座管柱尺寸: 外径

SEAT POST CLAMP: CS16

座管夹

BB: BB68

五通

WEIGHT: (WITH NO SEAT POST,WITH NO

重量 COSMETICS) 1020±20G (440MM)

AVAILABLE FRONT FORK: A:RF24

配置前叉

B:RF01,RF03,

RF04,RF06

RF10-S,

RF21-S

HEAD TUBE STIFFNESS: 95 Nm/0

头管刚性

BB STIFFNESS: 120 Nm/0

五通刚性

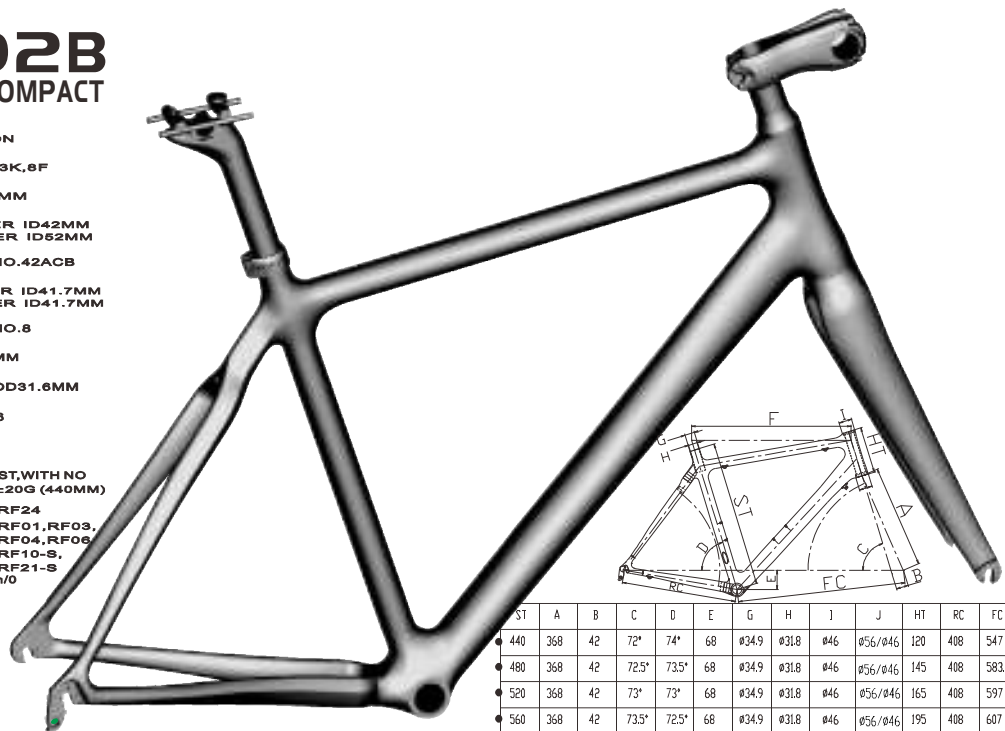

| ST  | A   | B  | C     | D     | E  | G     | H     | J   | J       | HT  | RC  | FC    |
|-----|-----|----|-------|-------|----|-------|-------|-----|---------|-----|-----|-------|
| 440 | 368 | 42 | 72°   | 74°   | 68 | ø34.9 | ø31.8 | ø46 | ø56/ø46 | 120 | 408 | 547   |
| 480 | 368 | 42 | 72.5° | 73.5° | 68 | ø34.9 | ø31.8 | ø46 | ø56/ø46 | 145 | 408 | 583.3 |
| 520 | 368 | 42 | 73°   | 73°   | 68 | ø34.9 | ø31.8 | ø46 | ø56/ø46 | 165 | 408 | 597   |
| 560 | 368 | 42 | 73.5° | 72.5° | 68 | ø34.9 | ø31.8 | ø46 | ø56/ø46 | 195 | 408 | 607   |

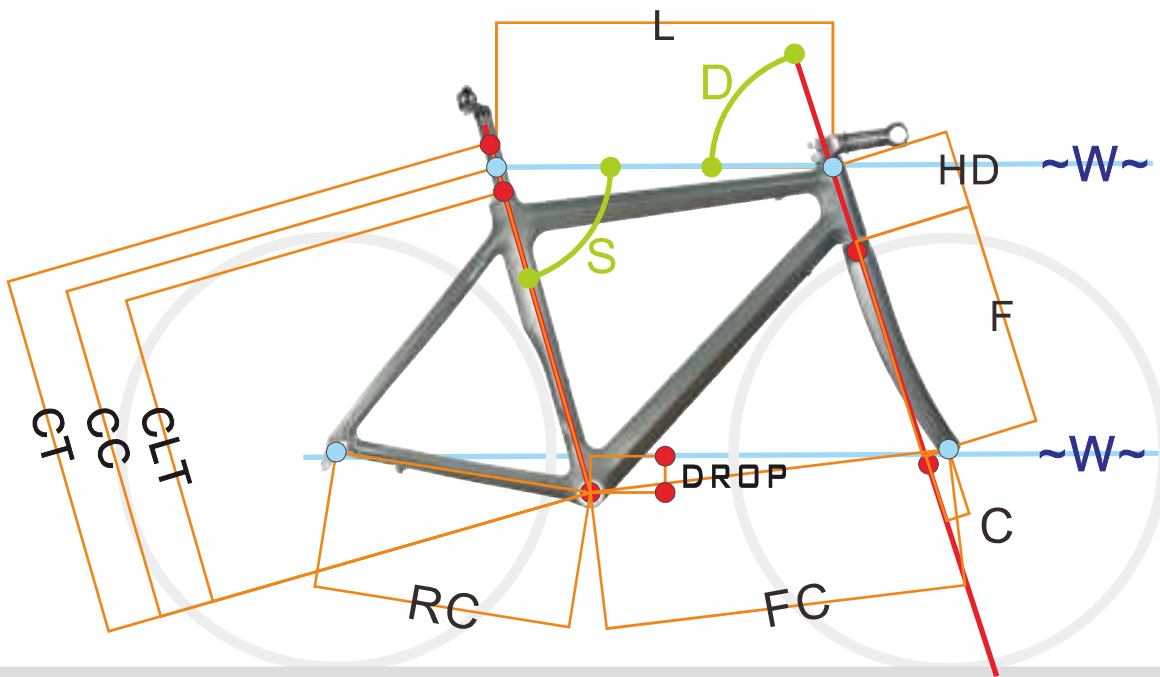

## 70 - 69 - 57 - 39 - 12 - 08

| CC  | CT  | RC  | L   | S    | D    | HD  | DROP | F   | C  |
|-----|-----|-----|-----|------|------|-----|------|-----|----|
| 470 | 490 | 402 | 518 | 75.2 | 71.0 | 108 | 70   | 367 | 43 |
| 500 | 520 | 402 | 531 | 74.2 | 71.5 | 115 | 70   | 367 | 43 |
| 520 | 540 | 402 | 540 | 74.0 | 72.0 | 133 | 70   | 367 | 43 |
| 540 | 560 | 402 | 550 | 74.0 | 73.0 | 150 | 70   | 367 | 43 |
| 560 | 580 | 402 | 565 | 73.0 | 73.5 | 166 | 70   | 367 | 43 |
| 590 | 610 | 402 | 575 | 73.0 | 73.5 | 196 | 70   | 367 | 43 |

## RLT-07 / 04

| CC  | CT  | RC  | L   | S    | D    | HD  | DROP | F   | C  |
|-----|-----|-----|-----|------|------|-----|------|-----|----|
| 500 | 530 | 408 | 534 | 74.5 | 73.0 | 115 | 68   | 367 | 43 |
| 530 | 560 | 408 | 540 | 73.5 | 73.0 | 135 | 68   | 367 | 43 |
| 550 | 580 | 408 | 561 | 73.0 | 73.5 | 150 | 68   | 367 | 43 |
| 590 | 620 | 408 | 591 | 73.0 | 73.7 | 185 | 68   | 367 | 43 |
| 620 | 650 | 408 | 612 | 72.5 | 74.0 | 200 | 68   | 367 | 43 |

## ROT-57

| CC | CT  | RC  | L   | S    | D    | HD  | DROP | F   | C  |
|----|-----|-----|-----|------|------|-----|------|-----|----|
|    | 480 | 405 | 520 | 74.8 | 71.2 | 105 | 70   | 367 | 43 |
|    | 500 | 405 | 525 | 74.3 | 71.2 | 110 | 70   | 367 | 43 |
|    | 520 | 405 | 537 | 74.0 | 72.0 | 115 | 70   | 367 | 43 |
|    | 540 | 405 | 543 | 74.0 | 72.5 | 135 | 70   | 367 | 43 |
|    | 560 | 405 | 555 | 73.5 | 73.5 | 150 | 70   | 367 | 43 |
|    | 580 | 405 | 570 | 73.5 | 73.5 | 180 | 70   | 367 | 43 |
|    | 600 | 405 | 582 | 73.5 | 73.5 | 190 | 70   | 367 | 43 |
|    | 620 | 405 | 588 | 73.0 | 73.5 | 210 | 70   | 367 | 43 |



# TIME TRIAL IRONMAN TRACK

**TOTR-59**  
**TOTT-65**

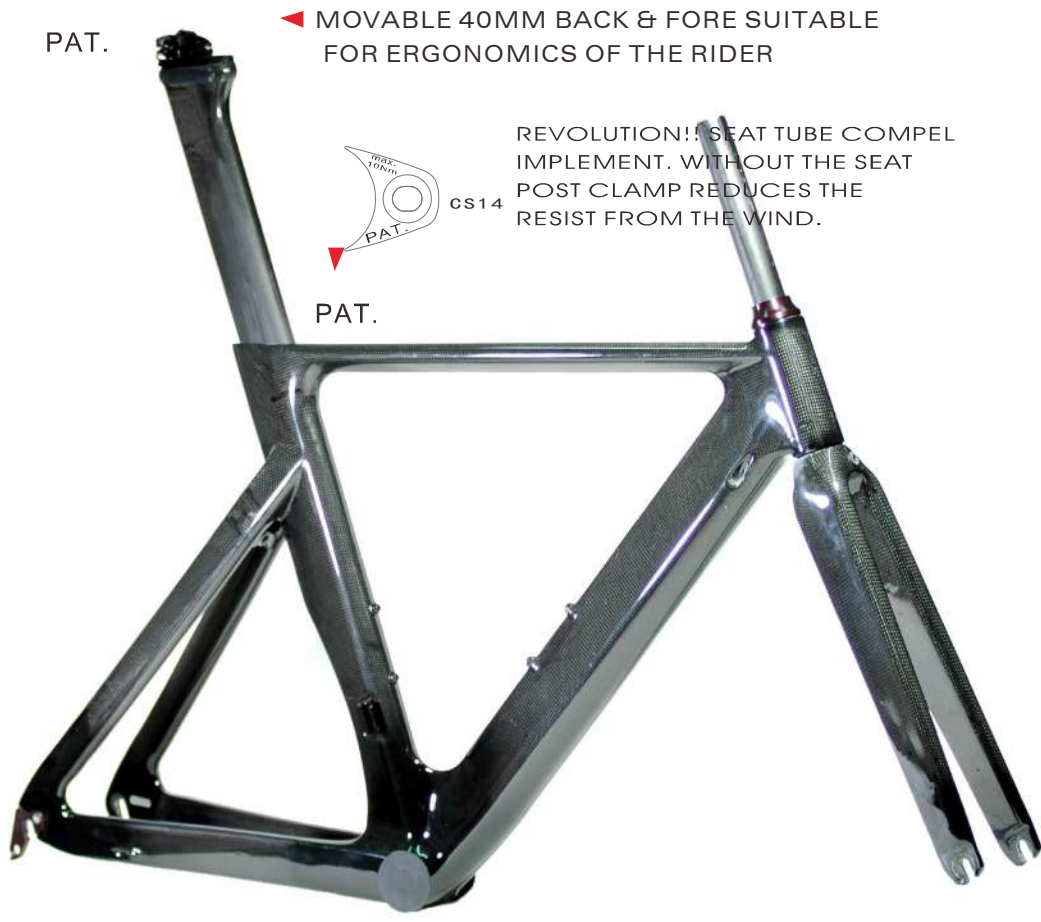

PAT.

◀ MOVABLE 40MM BACK & FORE SUITABLE FOR ERGONOMICS OF THE RIDER

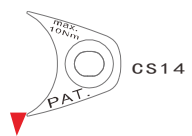

REVOLUTION!! SEAT TUBE COMPEL IMPLEMENT. WITHOUT THE SEAT POST CLAMP REDUCES THE RESIST FROM THE WIND.

PAT.

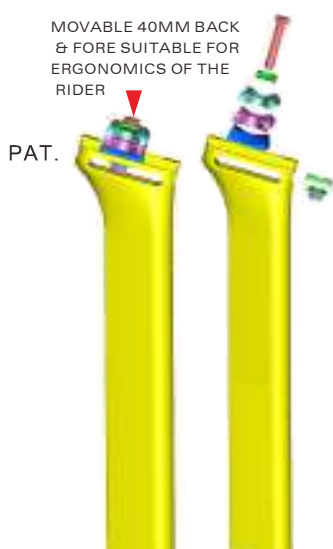

MOVABLE 40MM BACK & FORE SUITABLE FOR ERGONOMICS OF THE RIDER

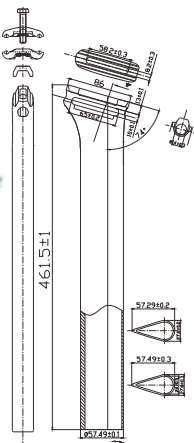

**TO14**

MATERIAL: 100% Carbon  
WEIGHT: 200 ± 5 g  
SCREW: M5 X 35mm : 1 PCS  
M5 X 35mm : 1 PCS

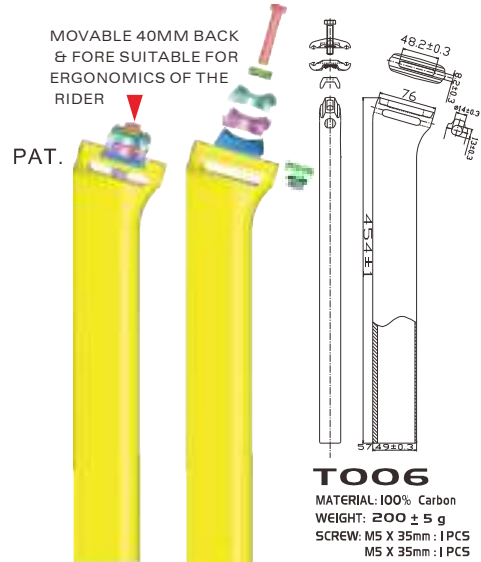

MOVABLE 40MM BACK & FORE SUITABLE FOR ERGONOMICS OF THE RIDER

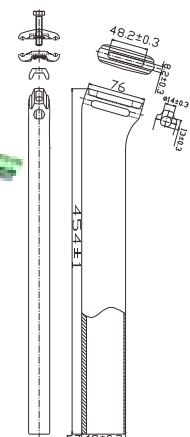

**TO06**

MATERIAL: 100% Carbon  
WEIGHT: 200 ± 5 g  
SCREW: M5 X 35mm : 1 PCS  
M5 X 35mm : 1 PCS

## TOTT-65

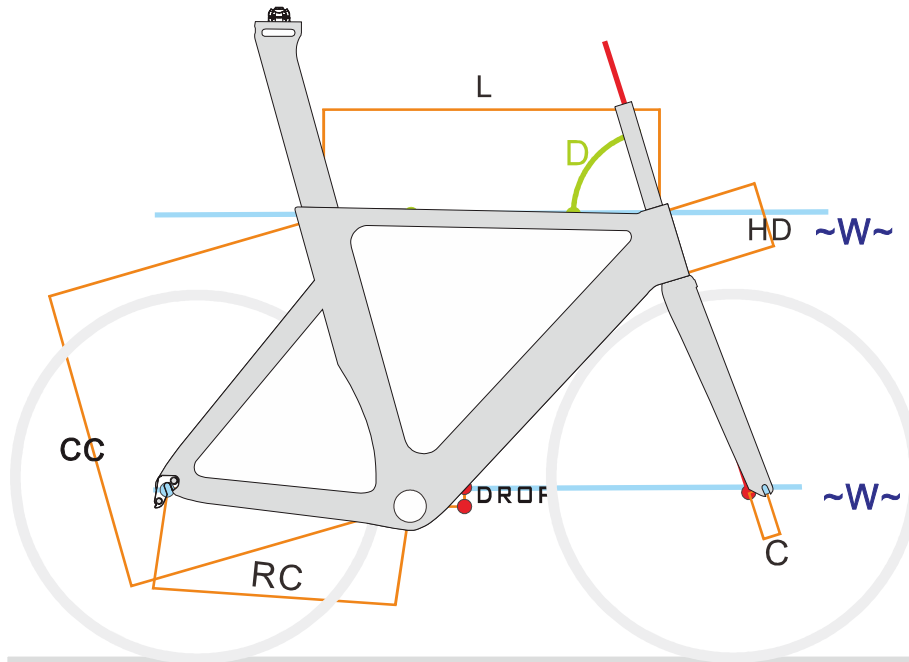

## TOTR-59 TOTT-65

| CC  | CT | RC  | L   | S    | D    | HD  | DROP | F   | C  |
|-----|----|-----|-----|------|------|-----|------|-----|----|
| 470 |    | 402 | 518 | 75.2 | 71.0 | 108 | 45   | 367 | 41 |
| 500 |    | 402 | 531 | 74.2 | 71.5 | 115 | 45   | 367 | 41 |
| 520 |    | 402 | 540 | 74.0 | 72.0 | 133 | 45   | 367 | 41 |
| 540 |    | 402 | 550 | 74.0 | 73.0 | 150 | 45   | 367 | 41 |
| 560 |    | 402 | 565 | 73.0 | 73.5 | 166 | 45   | 367 | 41 |
| 590 |    | 402 | 575 | 73.0 | 73.5 | 196 | 45   | 367 | 41 |



# COS 132

## MONOCOQUE COMPACT

一体成型

**MATERIAL:** 100% CARBON  
材质

**FINISH:** UD,6A,3A,12D,3K,8F  
外观

**SIZE:** 480,500,520,540,560,580,600,620MM  
尺寸

**BIG HEAD TUBE:** UPPER ID42MM  
大头管: 上端内径  
LOWER ID52MM  
下端内径

**HEAD TUBE SET:** FSA:NO.42ACB  
头管腕组: 天心

**SMALL HEAD TUBE:**  
小头管: 上端内径  
下端内径

**HEAD TUBE SET:**  
头管腕组: 天心

**SEAT TUBE SIZE:** ID31.8MM  
座管尺寸: 内径

**SEAT POST SIZE:** T008 / OD31.6MM  
座管柱尺寸: 外径

**SEAT POST CLAMP:** CS13/CS16  
座管束

**BB:** BB68  
五通

**WEIGHT:** (WITH NO SEAT POST, WITH NO  
重量 COSMETICS) 1100±20G (540MM)

**AVAILABLE FRONT FORK:** CF56  
配置前叉

**HEAD TUBE STIFFNESS:** 110 Nm/0  
头管刚性

**BB STIFFNESS:** 145 Nm/0  
五通刚性

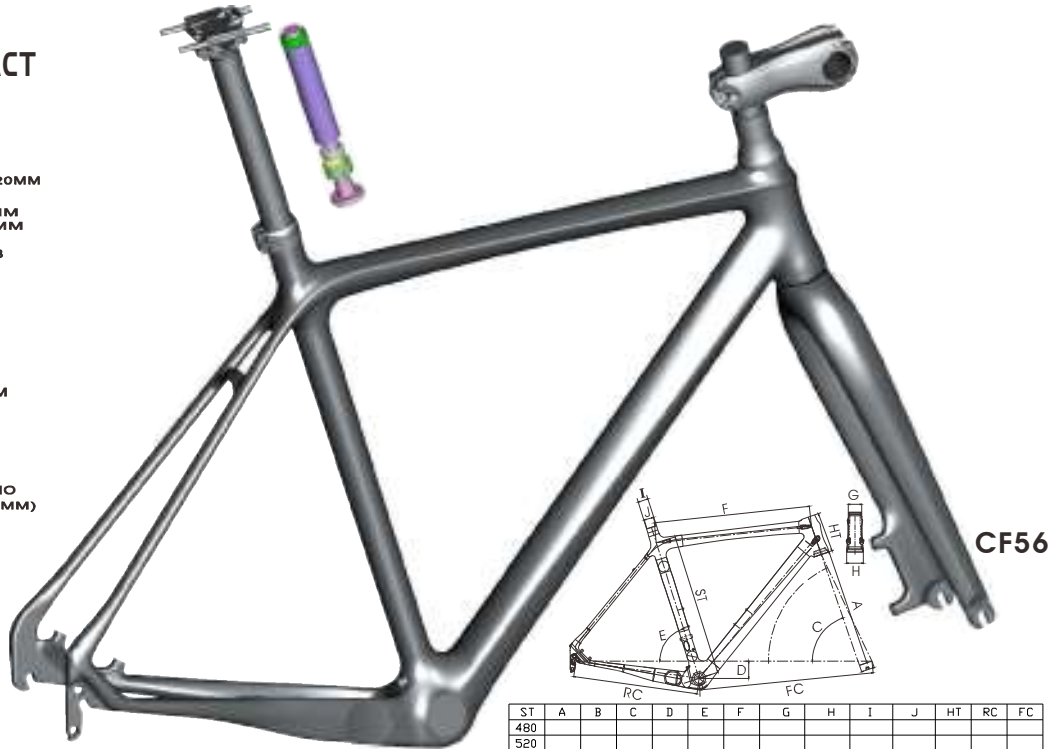

| ST    | A   | B  | C   | D  | E   | F   | G      | H      | I     | J     | HT  | RC  | FC    |
|-------|-----|----|-----|----|-----|-----|--------|--------|-------|-------|-----|-----|-------|
| 480   |     |    |     |    |     |     |        |        |       |       |     |     |       |
| 520   |     |    |     |    |     |     |        |        |       |       |     |     |       |
| ● 540 | 400 | 45 | 71* | 59 | 72* | 543 | ∅42/47 | ∅52/56 | ∅34.9 | ∅31.8 | 135 | 425 | 592.7 |
| 560   |     |    |     |    |     |     |        |        |       |       |     |     |       |

# COS 74

## MONOCOQUE COMPACT

一体成型

**MATERIAL:** 100% CARBON  
材质

**FINISH:** UD,6A,3A,12D,3K,8F  
外观

**SIZE:** 520,540,560,580MM  
尺寸

**BIG HEAD TUBE:** UPPER ID42MM  
大头管: 上端内径  
LOWER ID52MM  
下端内径

**HEAD TUBE SET:** FSA:NO.42ACB  
头管腕组: 天心

**SMALL HEAD TUBE:**  
小头管: 上端内径  
下端内径

**HEAD TUBE SET:**  
头管腕组: 天心

**SEAT TUBE SIZE:** ID31.8MM  
座管尺寸: 内径

**SEAT POST SIZE:** T008 / OD31.6MM  
座管柱尺寸: 外径

**SEAT POST CLAMP:** CS12  
座管束

**BB:** BB68  
五通

**WEIGHT:** (WITH NO SEAT POST, WITH NO  
重量 COSMETICS) 1110±20G (520MM)

**AVAILABLE FRONT FORK:** RF24  
配置前叉

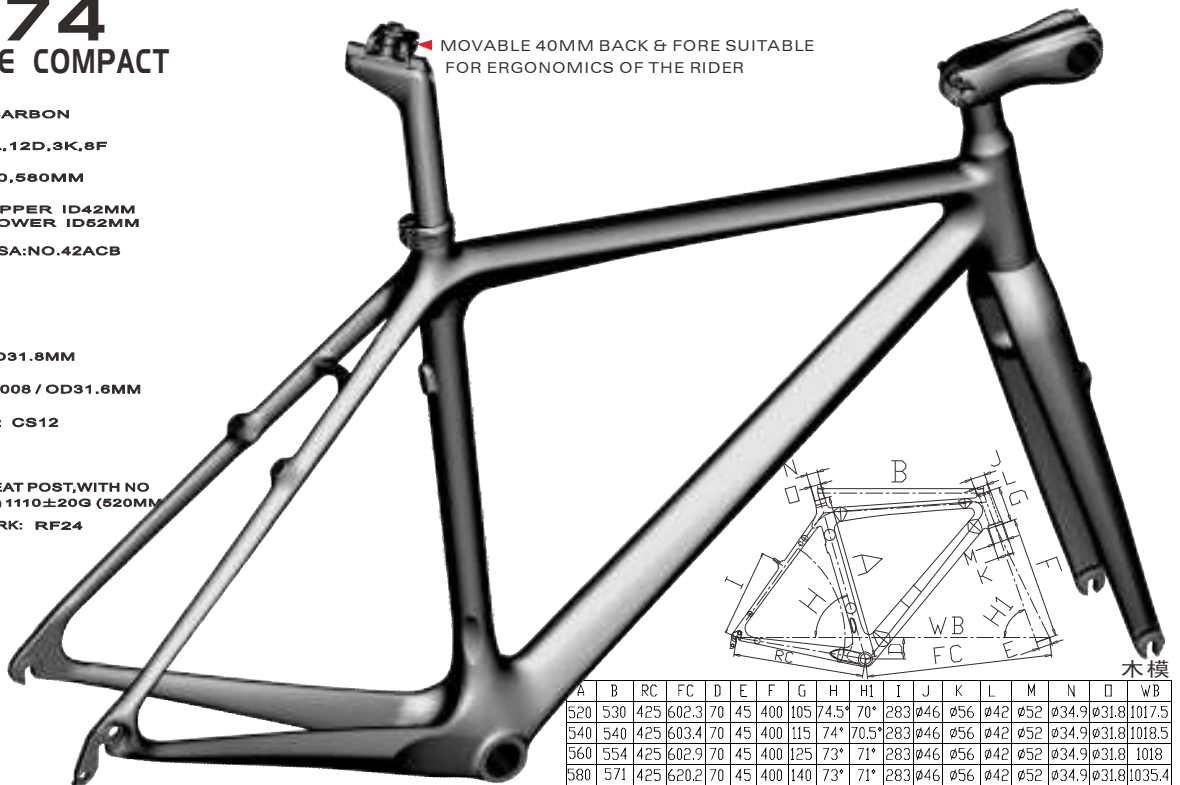

| A   | B   | RC  | FC    | D  | E  | F   | G   | H     | H1    | I   | J   | K   | L   | M   | N     | O     | WB     |
|-----|-----|-----|-------|----|----|-----|-----|-------|-------|-----|-----|-----|-----|-----|-------|-------|--------|
| 520 | 530 | 425 | 602.3 | 70 | 45 | 400 | 105 | 74.5* | 70*   | 283 | ∅46 | ∅56 | ∅42 | ∅52 | ∅34.9 | ∅31.8 | 1017.5 |
| 540 | 540 | 425 | 603.4 | 70 | 45 | 400 | 115 | 74*   | 70.5* | 283 | ∅46 | ∅56 | ∅42 | ∅52 | ∅34.9 | ∅31.8 | 1018.5 |
| 560 | 554 | 425 | 602.9 | 70 | 45 | 400 | 125 | 73*   | 71*   | 283 | ∅46 | ∅56 | ∅42 | ∅52 | ∅34.9 | ∅31.8 | 1018   |
| 580 | 571 | 425 | 620.2 | 70 | 45 | 400 | 140 | 73*   | 71*   | 283 | ∅46 | ∅56 | ∅42 | ∅52 | ∅34.9 | ∅31.8 | 1035.4 |

# MOS I36

## MONOCOQUE COMPACT

一体成型

MATERIAL: 100% CARBON  
材质

FINISH: UD,6A,3A,12D,3K,8F  
外观

SIZE: 400,440,480,520,560MM  
尺寸

BIG HEAD TUBE: A:UPPER ID42MM  
大头管: 上端内径 LOWER ID52MM  
下端内径

HEAD TUBE SET: FSA:NO.42ACB  
头管腕组: 天心

SMALL HEAD TUBE: B:UPPER ID41.7MM  
小头管: 上端内径 LOWER ID41.7MM  
下端内径

HEAD TUBE SET: FSA:NO.8  
头管腕组: 天心

SEAT TUBE SIZE: ID31.8MM  
座管尺寸: 内径

SEAT POST SIZE: T009 / OD31.6MM  
座管柱尺寸: 外径

SEAT POST CLAMP: CS16  
座管束

BB: BB68  
五通

WEIGHT: (WITH NO SEAT POST, WITH NO  
重量 COSMETICS) 1230±20G (480MM)

AVAILABLE FRONT FORK: MF59  
配置前叉

HEAD TUBE STIFFNESS: 103 Nm/0  
头管刚性

BB STIFFNESS: 130 Nm/0  
五通刚性

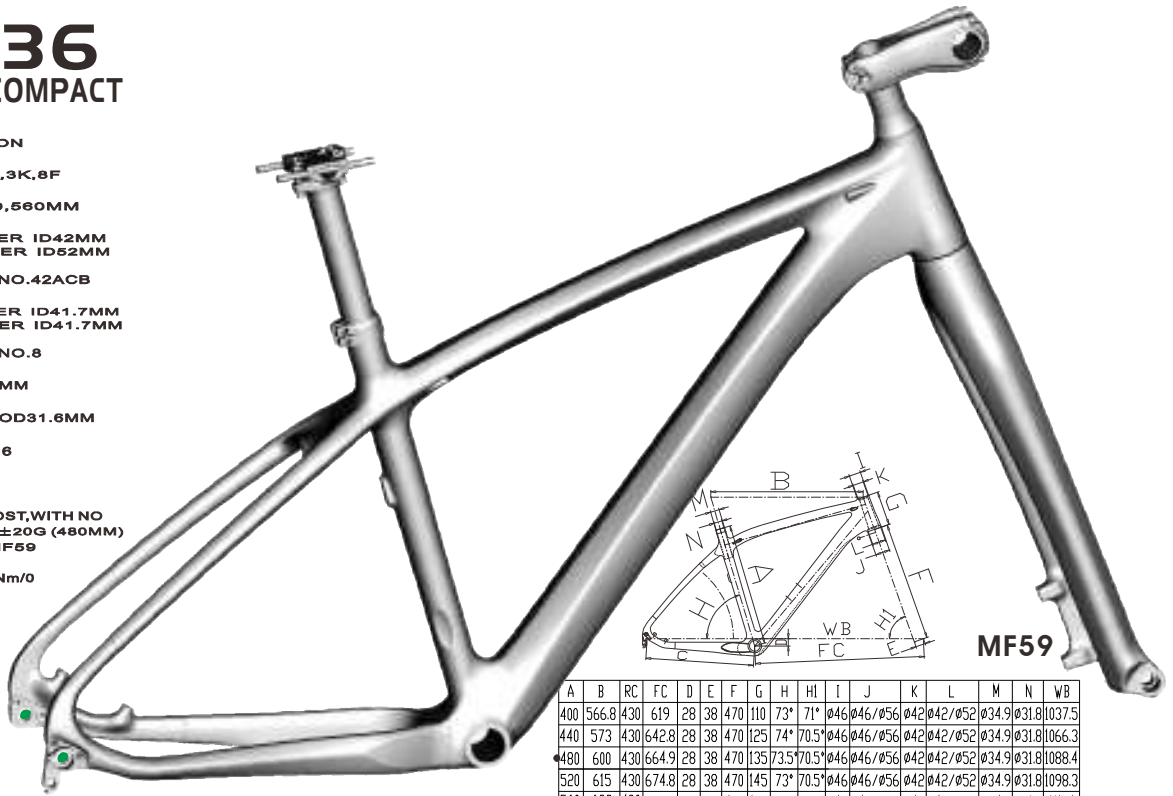

| A   | B     | RC  | FC    | D  | E  | F   | G   | H     | HI    | I   | J       | K   | L       | M     | N     | WB     |
|-----|-------|-----|-------|----|----|-----|-----|-------|-------|-----|---------|-----|---------|-------|-------|--------|
| 400 | 566.8 | 430 | 619   | 28 | 38 | 470 | 110 | 73°   | 71°   | 046 | 046/056 | 042 | 042/052 | 034.9 | 031.8 | 1037.5 |
| 440 | 573   | 430 | 642.8 | 28 | 38 | 470 | 125 | 74°   | 70.5° | 046 | 046/056 | 042 | 042/052 | 034.9 | 031.8 | 1066.3 |
| 480 | 600   | 430 | 664.9 | 28 | 38 | 470 | 135 | 73.5° | 70.5° | 046 | 046/056 | 042 | 042/052 | 034.9 | 031.8 | 1088.4 |
| 520 | 615   | 430 | 674.8 | 28 | 38 | 470 | 145 | 73°   | 70.5° | 046 | 046/056 | 042 | 042/052 | 034.9 | 031.8 | 1098.3 |
| 560 | 632   | 430 | 686.6 | 28 | 38 | 470 | 160 | 72.5° | 70.5° | 046 | 046/056 | 042 | 042/052 | 034.9 | 031.8 | 1110.1 |

# MOS I34

## MONOCOQUE COMPACT

一体成型

MATERIAL: 100% CARBON  
材质

FINISH: UD,6A,3A,12D,3K,8F  
外观

SIZE: 400,440,480,520,560MM  
尺寸

BIG HEAD TUBE: A:UPPER ID42MM  
大头管: 上端内径 LOWER ID52MM  
下端内径

HEAD TUBE SET: FSA:NO.42ACB  
头管腕组: 天心

SMALL HEAD TUBE: B:UPPER ID41.7MM  
小头管: 上端内径 LOWER ID41.7MM  
下端内径

HEAD TUBE SET: FSA:NO.8  
头管腕组: 天心

SEAT TUBE SIZE: ID31.8MM  
座管尺寸: 内径

SEAT POST SIZE: T009 / OD31.6MM  
座管柱尺寸: 外径

SEAT POST CLAMP: CS16  
座管束

BB: BB68  
五通

WEIGHT: (WITH NO SEAT POST, WITH NO  
重量 COSMETICS) 1230±20G (480MM)

AVAILABLE FRONT FORK: MF55  
配置前叉

HEAD TUBE STIFFNESS: 103 Nm/0  
头管刚性

BB STIFFNESS: 130 Nm/0  
五通刚性



| A   | B     | RC  | FC    | D  | E  | F   | G   | H     | HI    | I   | J       | K   | L       | M     | N     | WB     |
|-----|-------|-----|-------|----|----|-----|-----|-------|-------|-----|---------|-----|---------|-------|-------|--------|
| 400 | 566.8 | 430 | 619   | 28 | 38 | 470 | 110 | 73°   | 71°   | 046 | 046/056 | 042 | 042/052 | 034.9 | 031.8 | 1037.5 |
| 440 | 573   | 430 | 642.8 | 28 | 38 | 470 | 125 | 74°   | 70.5° | 046 | 046/056 | 042 | 042/052 | 034.9 | 031.8 | 1066.3 |
| 480 | 600   | 430 | 664.9 | 28 | 38 | 470 | 135 | 73.5° | 70.5° | 046 | 046/056 | 042 | 042/052 | 034.9 | 031.8 | 1088.4 |
| 520 | 615   | 430 | 674.8 | 28 | 38 | 470 | 145 | 73°   | 70.5° | 046 | 046/056 | 042 | 042/052 | 034.9 | 031.8 | 1098.3 |
| 560 | 632   | 430 | 686.6 | 28 | 38 | 470 | 160 | 72.5° | 70.5° | 046 | 046/056 | 042 | 042/052 | 034.9 | 031.8 | 1110.1 |

# MOS 107

## MONOCOQUE COMPACT

一体成型

**MATERIAL:** 100% CARBON  
材质

**FINISH:** UD,6A,3A,12D,3K,8F  
外观

**SIZE:** 406,457,496,533MM  
尺寸

**BIG HEAD TUBE:** A:UPPER ID42MM  
大头管:上端内径 LOWER ID52MM  
下端内径

**HEAD TUBE SET:** FSA:NO.42ACB  
头管腕组:天心

**SMALL HEAD TUBE:** B:UPPER ID41.7MM  
小头管:上端内径 LOWER ID41.7MM  
下端内径

**HEAD TUBE SET:** FSA:NO.8  
头管腕组:天心

**SEAT TUBE SIZE:** ID31.8MM  
座管尺寸:内径

**SEAT POST SIZE:** T009 / OD31.6MM  
座管柱尺寸:外径

**SEAT POST CLAMP:** CS16  
座管束

**BB:** BB30 BB68  
五通

**WEIGHT:** (WITH NO SEAT POST,WITH NO  
重量 COSMETICS) 1360±30G (457N)

**AVAILABLE FRONT FORK:**  
配置前叉

**HEAD TUBE STIFFNESS:** 130 Nm/Q  
头管刚性

**BB STIFFNESS:** 140 Nm/Q  
五通刚性



# MOS 90

## MONOCOQUE COMPACT

一体成型

**MATERIAL:** 100% CARBON  
材质

**FINISH:** UD,6A,3A,12D,3K,8F  
外观

**SIZE:** 400,440,480,520,560MM  
尺寸

**BIG HEAD TUBE:** A:UPPER ID42MM  
大头管:上端内径 LOWER ID52MM  
下端内径

**HEAD TUBE SET:** FSA:NO.42ACB  
头管腕组:天心

**SMALL HEAD TUBE:** B:UPPER ID41.7MM  
小头管:上端内径 LOWER ID41.7MM  
下端内径

**HEAD TUBE SET:** FSA:NO.8  
头管腕组:天心

**SEAT TUBE SIZE:** ID31.8MM  
座管尺寸:内径

**SEAT POST SIZE:** T009 / OD31.6MM  
座管柱尺寸:外径

**SEAT POST CLAMP:** CS16  
座管束

**BB:** BB30 BB68  
五通

**WEIGHT:** (WITH NO SEAT POST,WITH NO  
重量 COSMETICS) 1230±20G (480MM)

**HEAD TUBE STIFFNESS:** 103 Nm/Q  
头管刚性

**BB STIFFNESS:** 130 Nm/Q  
五通刚性

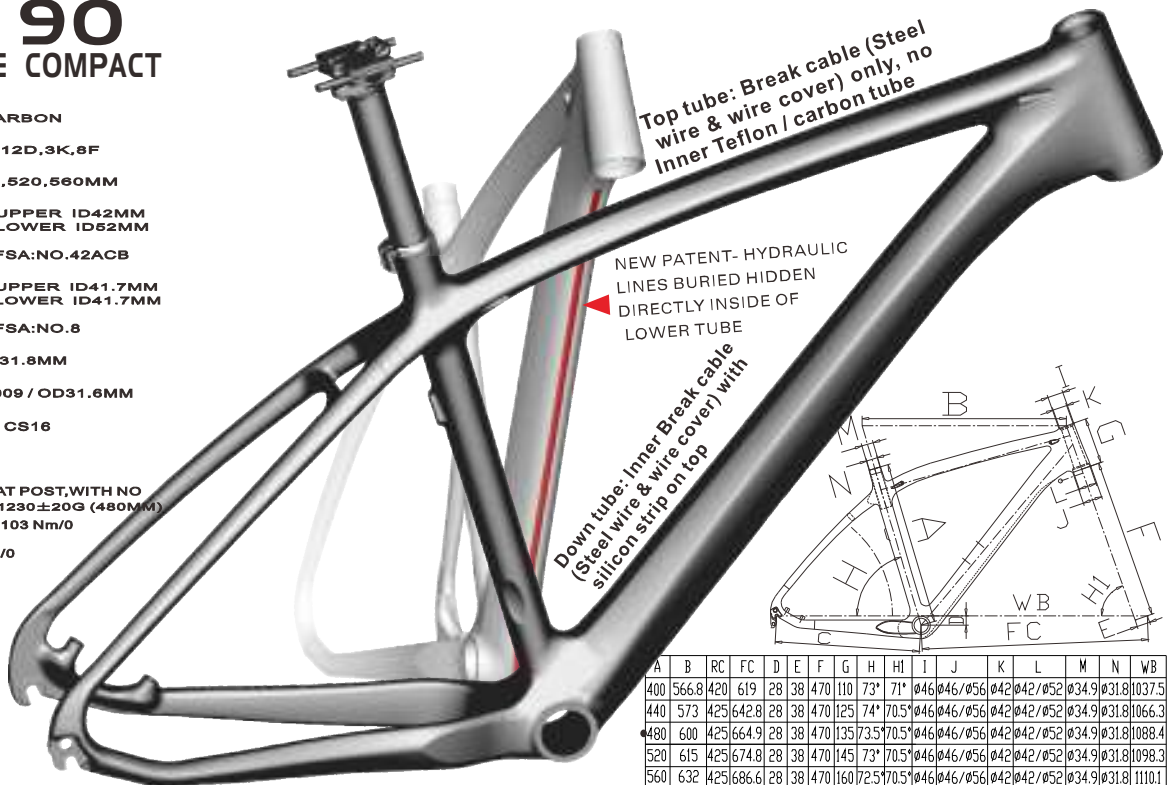

| A   | B     | RC  | FC    | D  | E  | F   | G   | H     | HI    | I   | J       | K   | L       | M     | N     | WB     |
|-----|-------|-----|-------|----|----|-----|-----|-------|-------|-----|---------|-----|---------|-------|-------|--------|
| 400 | 566.8 | 420 | 619   | 28 | 38 | 470 | 110 | 73*   | 71*   | 046 | 046/056 | 042 | 042/052 | 034.9 | 031.8 | 1037.5 |
| 440 | 573   | 425 | 642.8 | 28 | 38 | 470 | 125 | 74*   | 70.5* | 046 | 046/056 | 042 | 042/052 | 034.9 | 031.8 | 1066.3 |
| 480 | 600   | 425 | 664.9 | 28 | 38 | 470 | 135 | 73.5* | 70.5* | 046 | 046/056 | 042 | 042/052 | 034.9 | 031.8 | 1088.4 |
| 520 | 615   | 425 | 674.8 | 28 | 38 | 470 | 145 | 73*   | 70.5* | 046 | 046/056 | 042 | 042/052 | 034.9 | 031.8 | 1098.3 |
| 560 | 632   | 425 | 686.6 | 28 | 38 | 470 | 160 | 72.5* | 70.5* | 046 | 046/056 | 042 | 042/052 | 034.9 | 031.8 | 1110.1 |

## MO-61 (Disc)

Headset: Campagnolo 45 x 45  
 And 44 mm Head Tube  
 Seat Post: 27.2 / 31.6 mm  
 Size: 42 / 46 / 51 / 60 cm

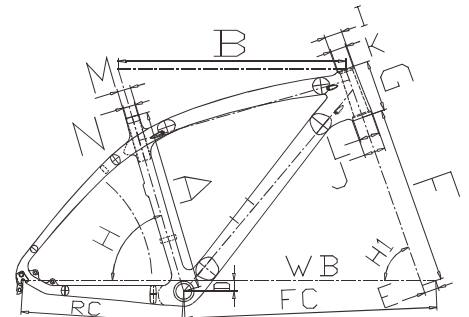

| A   | B     | RC  | FC    | D  | E  | F   | G   | H     | HI    | I   | J       | K   | L       | M     | N     | WB     |
|-----|-------|-----|-------|----|----|-----|-----|-------|-------|-----|---------|-----|---------|-------|-------|--------|
| 381 | 566.8 | 420 | 619   | 28 | 38 | 470 | 110 | 73°   | 71°   | 046 | 046/056 | 042 | 042/052 | 034.9 | 031.8 | 1037.5 |
| 400 | 566.8 | 420 | 619   | 28 | 38 | 470 | 110 | 73°   | 71°   | 046 | 046/056 | 042 | 042/052 | 034.9 | 031.8 | 1037.5 |
| 440 | 573   | 425 | 642.8 | 28 | 38 | 470 | 125 | 74°   | 70.5° | 046 | 046/056 | 042 | 042/052 | 034.9 | 031.8 | 1066.3 |
| 480 | 600   | 425 | 664.9 | 28 | 38 | 470 | 135 | 73.5° | 70.5° | 046 | 046/056 | 042 | 042/052 | 034.9 | 031.8 | 1088.4 |
| 520 | 615   | 425 | 674.8 | 28 | 38 | 470 | 145 | 73°   | 70.5° | 046 | 046/056 | 042 | 042/052 | 034.9 | 031.8 | 1098.3 |
| 560 | 632   | 425 | 686.6 | 28 | 38 | 470 | 160 | 72.5° | 70.5° | 046 | 046/056 | 042 | 042/052 | 034.9 | 031.8 | 1110.1 |

## MOS 06 MONOCOQUE COMPACT 一体成型

**MATERIAL: 100% CARBON**  
 材质

**FINISH: UD,6A,3A,12D,3K,8F**  
 外观

**SIZE: 440,480,520,560MM**  
 尺寸

**BIG HEAD TUBE:**  
 大头管: 上端内径  
 下端内径

**HEAD TUBE SET:**  
 头管脑组: 天心

**SMALL HEAD TUBE:** UPPER ID41.7MM  
 小头管: 上端内径  
 下端内径

**HEAD TUBE SET:** FSA:NO.8  
 头管脑组: 天心

**SEAT TUBE SIZE:** ID31.8MM  
 座管尺寸: 内径

**SEAT POST SIZE:** T009 / OD31.6MM  
 座管柱尺寸: 外径

**SEAT POST CLAMP:** CS16  
 座管束

**BB: BB68**  
 五通

**WEIGHT: (WITH NO SEAT POST, WITH NO  
 重量 COSMETICS) 1300±20G (520MM)**

**HEAD TUBE STIFFNESS:** 150 Nm/O  
 头管刚度

**BB STIFFNESS:** 145 Nm/O  
 五通刚度

**THIS MODEL IS PROHIBITED TO SELL  
 TO GERMANY, SWISS & AUSTRIA.**

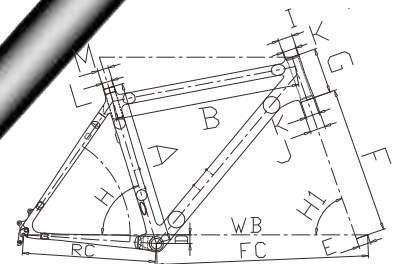

| A   | B     | RC  | FC    | D  | E  | F   | G   | H     | HI    | I   | J     | K   | L     | M     | WB     |
|-----|-------|-----|-------|----|----|-----|-----|-------|-------|-----|-------|-----|-------|-------|--------|
| 440 | 552.8 | 425 | 642.8 | 28 | 38 | 470 | 125 | 74°   | 70.5° | 046 | 048.5 | 042 | 031.8 | 034.9 | 1066.3 |
| 480 | 577.6 | 425 | 664.9 | 28 | 38 | 470 | 135 | 73.5° | 70.5° | 046 | 048.5 | 042 | 031.8 | 034.9 | 1088.4 |
| 520 | 593   | 425 | 674.8 | 28 | 38 | 470 | 145 | 73°   | 70.5° | 046 | 048.5 | 042 | 031.8 | 034.9 | 1098.3 |
| 560 | 611.8 | 425 | 686.6 | 28 | 38 | 470 | 160 | 72.5° | 70.5° | 046 | 048.5 | 042 | 031.8 | 034.9 | 1110.1 |

**MO-01N (V-BRAKE / DISC)**

Material: 100% Carbon Fiber

Weight: 1250±50 g

Headset: Campagnolo 45 x 45  
And 44 mm Head Tube

Seat Post: 27.2 / 31.6 mm

Size: 42 / 46 / 51 / 60 cm



● CARBON

**MO-05 (Disc)**

Material: 100% Carbon Fiber

Weight: 1250±50 g

Headset: Campagnolo 45 x 45  
And 44 mm Head Tube

Seat Post: 27.2 / 31.6 mm

Size: 42 / 46 / 51 / 60 cm



● CARBON



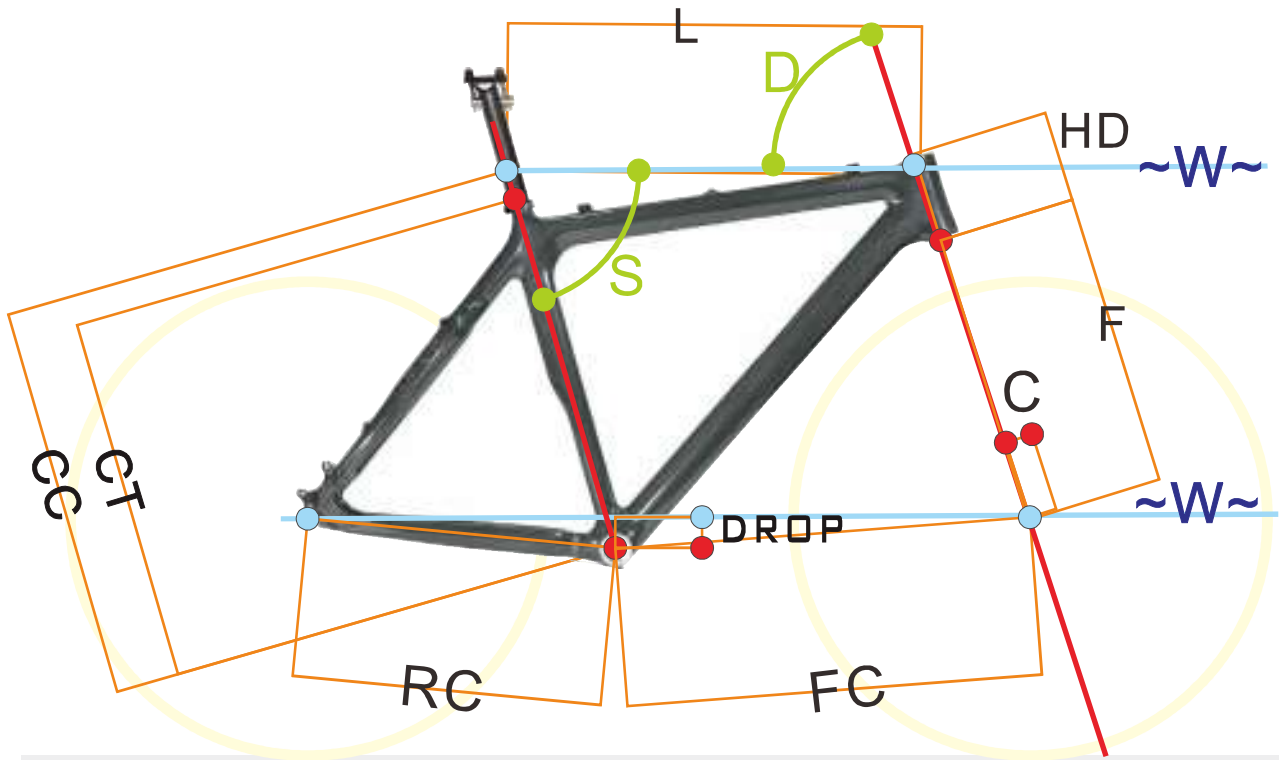

**MO-61**

| CT  | CT'' | RC  | L   | S    | D    | HD  | DROP | F   | C  |
|-----|------|-----|-----|------|------|-----|------|-----|----|
| 440 | 17.0 | 425 | 573 | 74.0 | 70.5 | 125 | 28   | 470 | 38 |
| 480 | 19.0 | 425 | 600 | 73.5 | 70.5 | 135 | 28   | 470 | 38 |
| 520 | 20.5 | 425 | 615 | 73.0 | 70.5 | 145 | 28   | 470 | 38 |
| 560 | 22.0 | 425 | 632 | 72.5 | 70.5 | 160 | 28   | 470 | 38 |

**MO-01N / MO-05**

| CT  | CT'' | RC  | L   | S    | D    | HD  | DROP | F   | C  |
|-----|------|-----|-----|------|------|-----|------|-----|----|
| 420 | 16.5 | 425 | 565 | 74.0 | 71.0 | 120 | 35   | 435 | 38 |
| 460 | 18.0 | 425 | 575 | 73.0 | 71.0 | 125 | 35   | 435 | 38 |
| 510 | 20.0 | 425 | 585 | 73.0 | 71.0 | 130 | 70   | 435 | 38 |
| 600 | 23.5 | 425 | 595 | 73.0 | 71.0 | 140 | 70   | 435 | 38 |

## DOS 66 MONOCOQUE COMPACT

一体成型

MATERIAL: 100% CARBON

材质

FINISH: UD,6A,3A,12D,3K,8F

外观

SIZE: 406,457,508MM

尺寸

BIG HEAD TUBE:

大头管: 上端内径

下端内径

HEAD TUBE SET:

头管腕组: 天心

SMALL HEAD TUBE: UPPER ID41.7MM

小头管: 上端内径

下端内径

HEAD TUBE SET: FSA:NO.8

头管腕组: 天心

SEAT TUBE SIZE: ID31.8MM

座管尺寸: 内径

SEAT POST SIZE: T009/OD31.6MM

座管柱尺寸: 外径

SEAT POST CLAMP: CS12

座管束

BB: BB68

五通

WEIGHT: (WITH NO SEAT POST, WITH NO

重量 COSMETICS) 1920±20G (457MM)

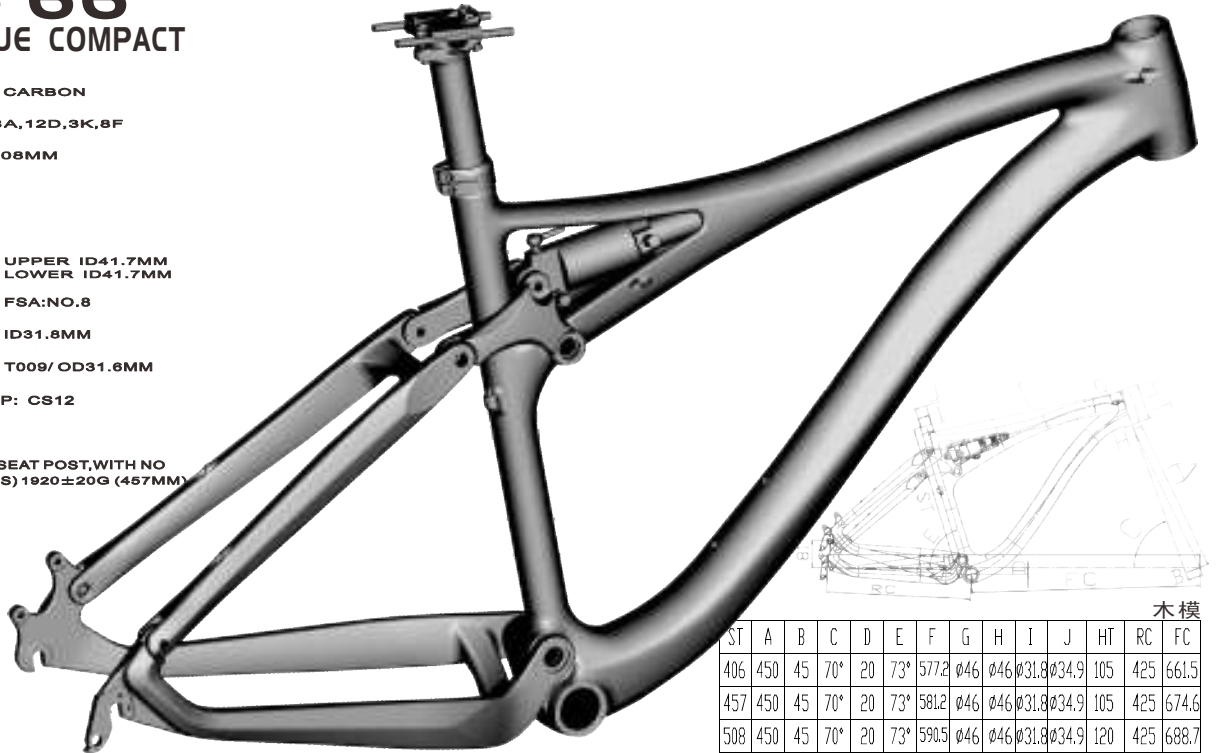

木模

| ST  | A   | B  | C   | D  | E   | F     | G   | H   | I     | J     | HT  | RC  | FC    |
|-----|-----|----|-----|----|-----|-------|-----|-----|-------|-------|-----|-----|-------|
| 406 | 450 | 45 | 70° | 20 | 73° | 577.2 | ø46 | ø46 | ø31.8 | ø34.9 | 105 | 425 | 661.5 |
| 457 | 450 | 45 | 70° | 20 | 73° | 581.2 | ø46 | ø46 | ø31.8 | ø34.9 | 105 | 425 | 674.6 |
| 508 | 450 | 45 | 70° | 20 | 73° | 590.5 | ø46 | ø46 | ø31.8 | ø34.9 | 120 | 425 | 688.7 |

## CITY BIKE

## COD 23 MONOCOQUE COMPACT

一体成型

MATERIAL: 100% CARBON

材质

FINISH: UD,6A,3A,12D,3K,8F

外观

SIZE: 500,550,600MM

尺寸

BIG HEAD TUBE:

大头管: 上端内径

下端内径

HEAD TUBE SET:

头管腕组: 天心

SMALL HEAD TUBE: UPPER ID41.7MM

小头管: 上端内径

下端内径

HEAD TUBE SET: FSA:NO.8

头管腕组: 天心

SEAT TUBE SIZE: ID31.8MM

座管尺寸: 内径

SEAT POST SIZE:

座管柱尺寸: 外径

SEAT POST CLAMP:

座管束

BB: BB68

五通

WEIGHT: (WITH NO SEAT POST, WITH NO

重量 COSMETICS) 1202±30G (500MM)

AVAILABLE FRONT FORK: CFD 07

配置前叉

HEAD TUBE STIFFNESS: 120 Nm/0

头管刚性

BB STIFFNESS: 130 Nm/0

五通刚性

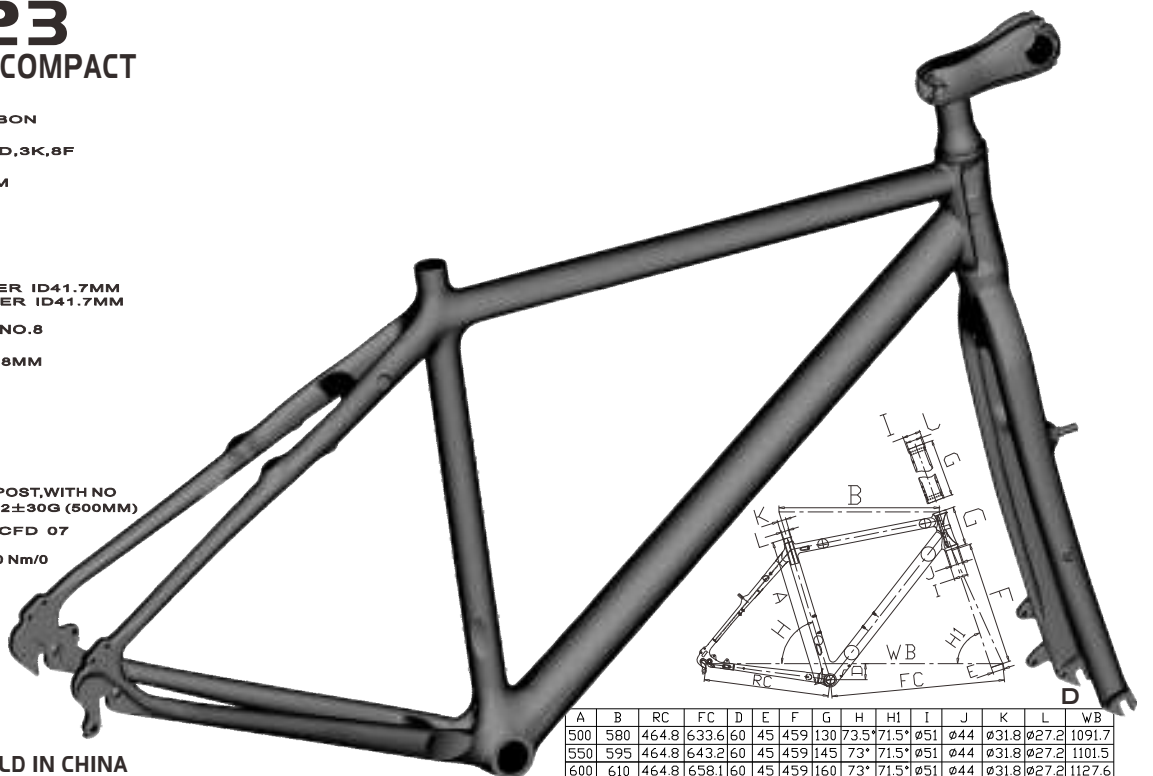

THIS MODEL IS SOLD IN CHINA

| A   | B   | RC    | FC    | D  | E  | F   | G   | H     | HI    | I   | J   | K     | L     | WB     |
|-----|-----|-------|-------|----|----|-----|-----|-------|-------|-----|-----|-------|-------|--------|
| 500 | 580 | 464.8 | 633.6 | 60 | 45 | 459 | 130 | 73.5° | 71.5° | ø51 | ø44 | ø31.8 | ø27.2 | 1091.7 |
| 550 | 595 | 464.8 | 643.2 | 60 | 45 | 459 | 145 | 73°   | 71.5° | ø51 | ø44 | ø31.8 | ø27.2 | 1101.5 |
| 600 | 610 | 464.8 | 658.1 | 60 | 45 | 459 | 160 | 73°   | 71.5° | ø51 | ø44 | ø31.8 | ø27.2 | 1127.6 |

## COD 15

### MONOCOQUE COMPACT

一体成型

MATERIAL: 100% CARBON  
材质

FINISH: UD,6A,3A,12D,3K,8F  
外观

SIZE: 450,500,550MM  
尺寸

BIG HEAD TUBE:  
大头管: 上端内径  
                  下端内径

HEAD TUBE SET:  
头管腕组: 天心

SMALL HEAD TUBE: UPPER ID41.7MM  
小头管: 上端内径  
                  LOWER ID41.7MM  
                  下端内径

HEAD TUBE SET: FSA:NO.8  
头管腕组: 天心

SEAT TUBE SIZE: ID31.8MM  
座管尺寸: 内径

SEAT POST SIZE:  
座管柱尺寸: 外径

SEAT POST CLAMP:  
座管束

BB: BB68  
五通

WEIGHT: (WITH NO SEAT POST, WITH NO  
重量 COSMETICS) 1400±20G (500MM)

AVAILABLE FRONT FORK: CFD 07  
配置前叉

HEAD TUBE STIFFNESS: 110 Nm/0  
头管刚性

BB STIFFNESS: 130 Nm/0  
五通刚性

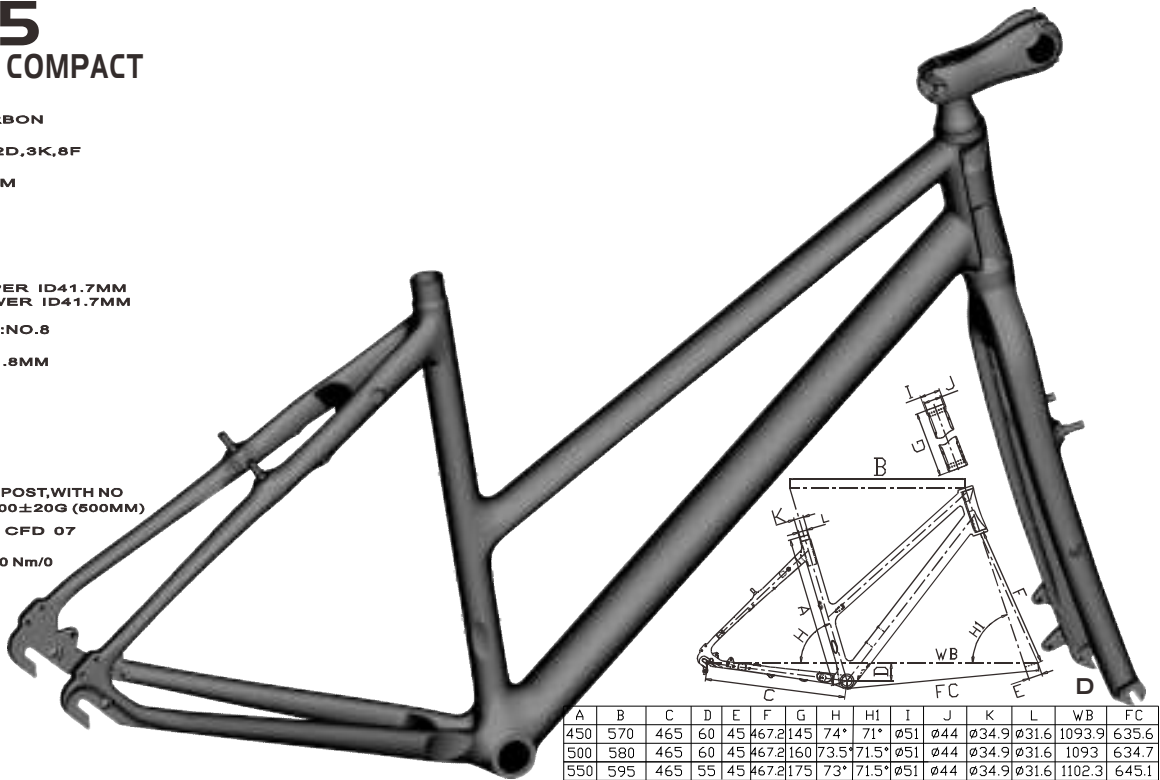

## COD 21

### MONOCOQUE COMPACT

一体成型

MATERIAL: 100% CARBON  
材质

FINISH: UD,6A,3A,12D,3K,8F  
外观

SIZE: 450,500,550MM  
尺寸

BIG HEAD TUBE:  
大头管: 上端内径  
                  下端内径

HEAD TUBE SET:  
头管腕组: 天心

SMALL HEAD TUBE: UPPER ID41.7MM  
小头管: 上端内径  
                  LOWER ID41.7MM  
                  下端内径

HEAD TUBE SET: FSA:NO.8  
头管腕组: 天心

SEAT TUBE SIZE: ID31.8MM  
座管尺寸: 内径

SEAT POST SIZE:  
座管柱尺寸: 外径

SEAT POST CLAMP:  
座管束

BB: BB68  
五通

WEIGHT: (WITH NO SEAT POST, WITH NO  
重量 COSMETICS) 1730±30G (500MM)

AVAILABLE FRONT FORK: CFD 07  
配置前叉

HEAD TUBE STIFFNESS: 120 Nm/0  
头管刚性

BB STIFFNESS: 130 Nm/0  
五通刚性

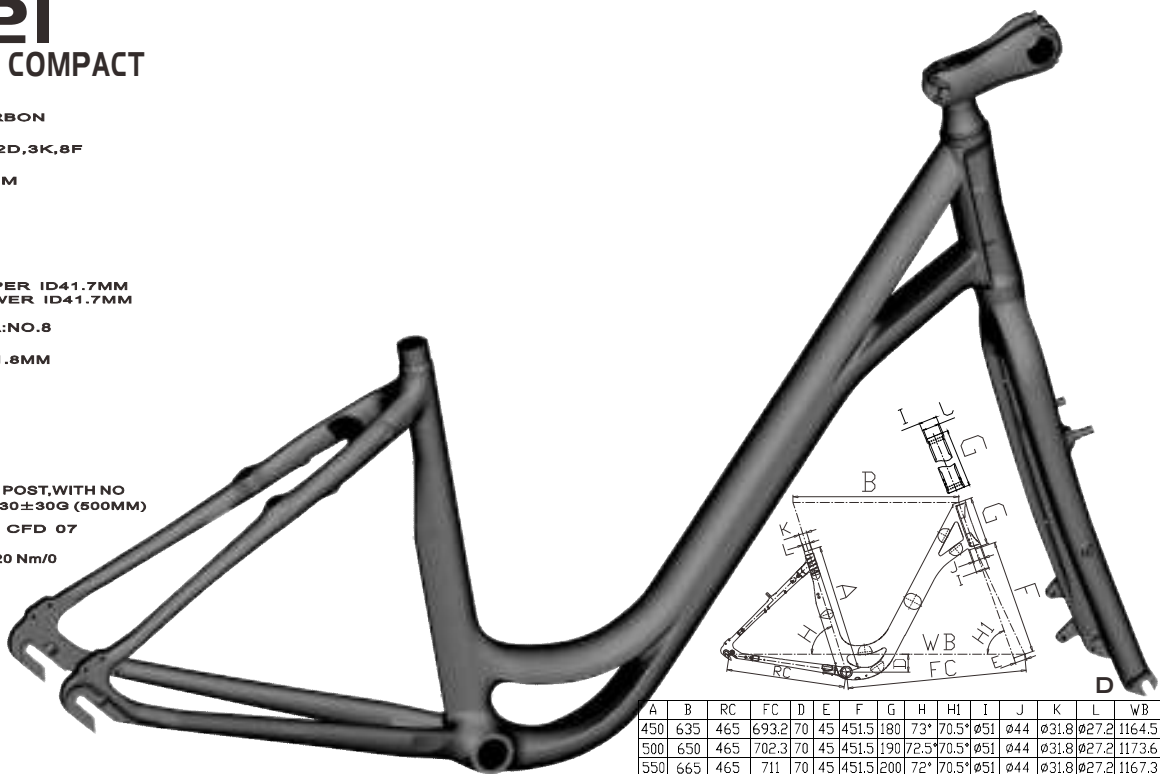

## BE-01

Material: Carbon / 6061 T6  
+ 7075 T6 SCREW

Weight: 72 g

Length : 70 mm



## BE-02

Material: Carbon / 6061 T6  
+ 7075 T6 SCREW

Weight: 82 g

Length : 100 mm



# HANDLEBARS

## HDM-01

Material:  
100% Carbon fiber  
Weight:  
200±10 g



## HDM-02

Material:  
100% Carbon fiber  
Weight:  
190±10 g





F-01



F-02



F-04

Material: 100% carbon Monocoque  
Fork Stem: Carbon  
Pivot: Carbon

Height : 300mm  
Weight: 380±20g  
Wheel: 700c

ROAD FORK



F-05  
7075 / 7050  
Aluminum stem



F-10



F-11



**F-21**



**F-23**



**F-38-39**



**F-40**

Material: 100% carbon Monocoque  
Fork Stem: Carbon  
Pivot : Carbon

Height : 300mm  
Weight: 420±20g  
Wheel: 700c

**T.T.**

**FORK TRAVEL**



**F-26**



**F-14**



**F-15**

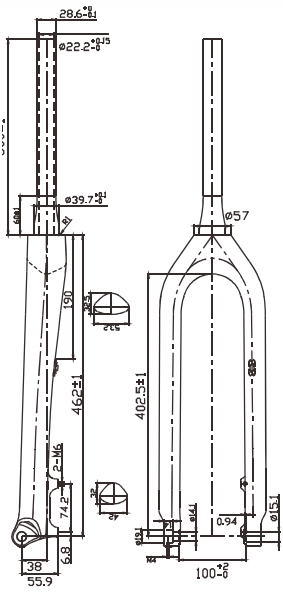
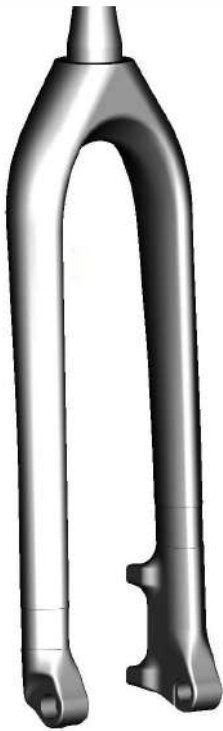

**MF 59 配车架M0S136**  
 FORKS: For 27.5"  
 MATERIAL :100% carbon  
 Carbon drop out  
 WEIGHTS:690±10g

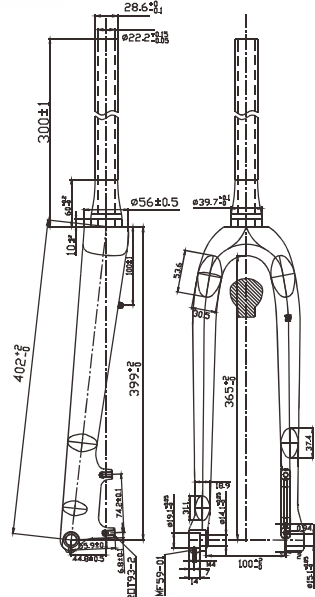

**CF 60 配车架C0S137**  
 FORKS: CYCLOCROSS  
 MATERIAL :100% carbon  
 Carbon drop out  
 WEIGHTS:570±10g

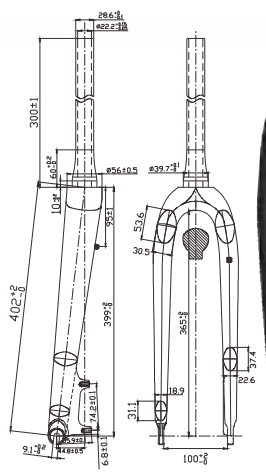

**CF 56 配车架C0S132**  
 FORKS: For 700C wheel  
 MATERIAL :100% carbon  
 Carbon drop out  
 WEIGHTS:570±10g

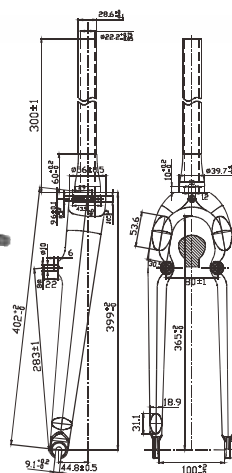

**CF 57 配车架C0S133**  
 FORKS: For 700C wheel  
 MATERIAL :100% carbon  
 Carbon drop out  
 WEIGHTS: 9

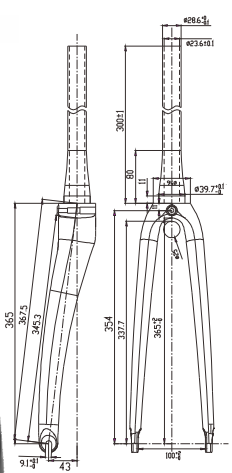

**RF 58 样品**  
 FORKS: For 700C wheel  
 MATERIAL :100% carbon  
 Carbon drop out  
 WEIGHTS: 9

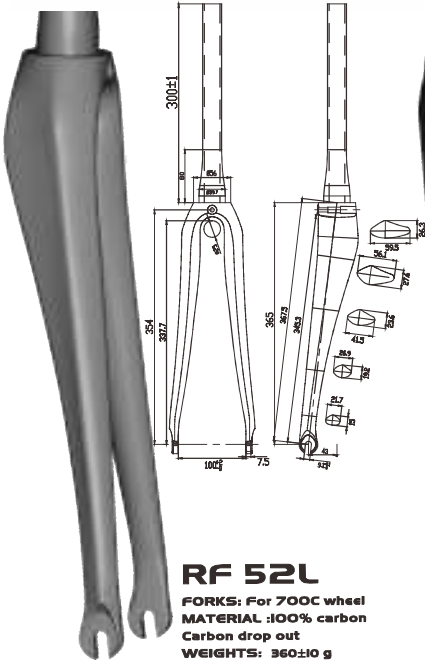

**RF 52L**  
**FORKS:** For 700C wheel  
**MATERIAL:** 100% carbon  
**Carbon drop out**  
**WEIGHTS:** 360±10 g

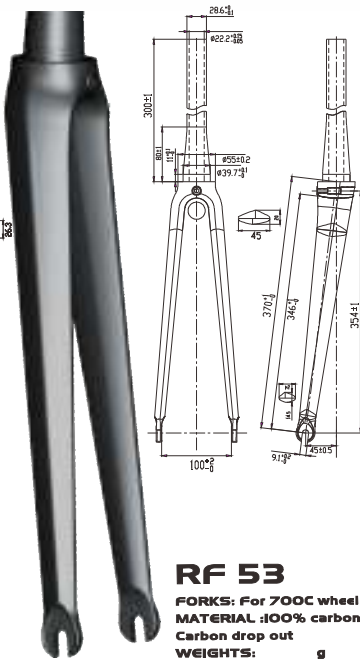

**RF 53**  
**FORKS:** For 700C wheel  
**MATERIAL:** 100% carbon  
**Carbon drop out**  
**WEIGHTS:** 9 g

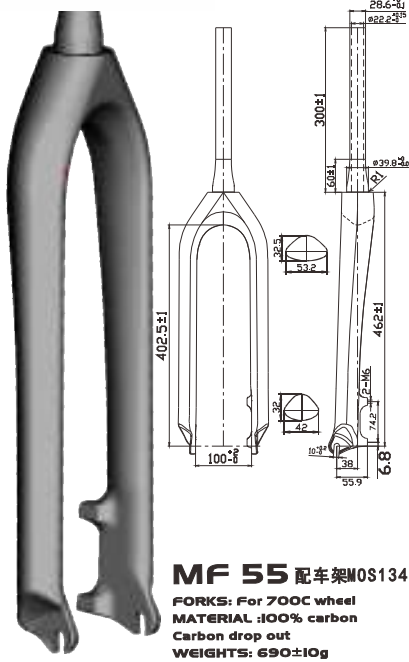

**MF 55 配车架M0S134**  
**FORKS:** For 700C wheel  
**MATERIAL:** 100% carbon  
**Carbon drop out**  
**WEIGHTS:** 690±10 g

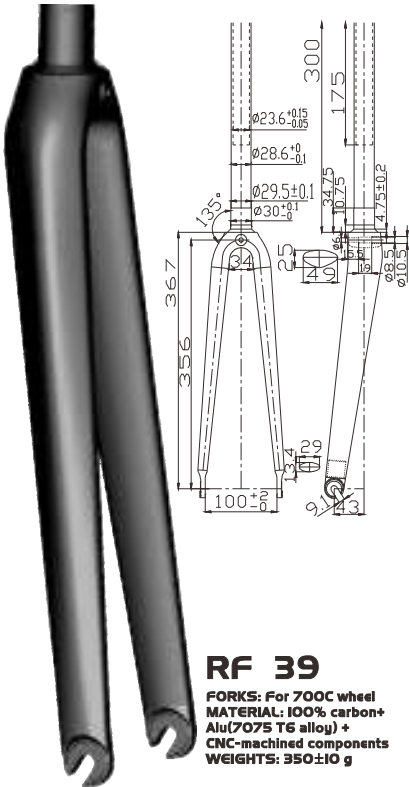

**RF 39**  
**FORKS:** For 700C wheel  
**MATERIAL:** 100% carbon +  
 Alu(7075 T6 alloy) +  
 CNC-machined components  
**WEIGHTS:** 350±10 g

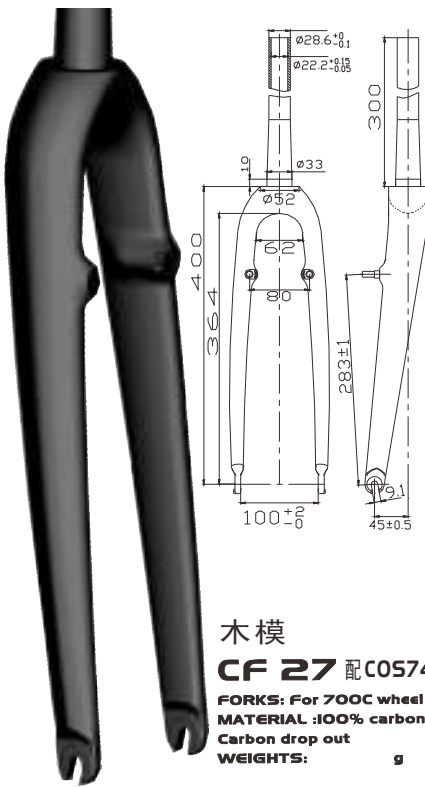

**木模**  
**CF 27 配C0S74车架**  
**FORKS:** For 700C wheel  
**MATERIAL:** 100% carbon  
**Carbon drop out**  
**WEIGHTS:** 9 g

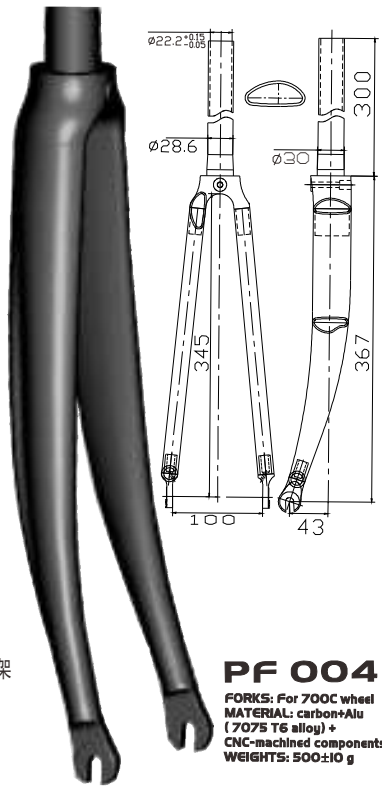

**PF 004**  
**FORKS:** For 700C wheel  
**MATERIAL:** carbon+Alu  
 (7075 T6 alloy) +  
 CNC-machined components  
**WEIGHTS:** 500±10 g



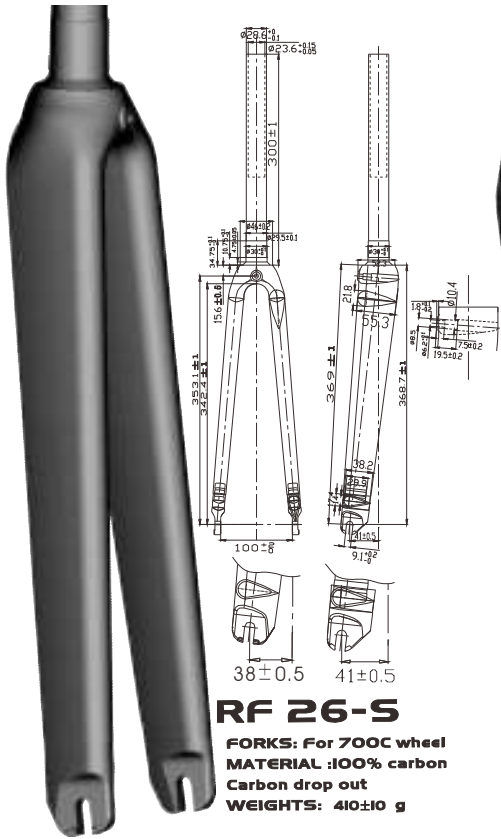

**RF 26-S**

**FORKS:** For 700C wheel  
**MATERIAL:** 100% carbon  
 Carbon drop out  
**WEIGHTS:** 410±10 g



**木模**

**RF 30 配T0577车架**

**FORKS:** For 700C wheel  
**MATERIAL:** 100% carbon  
 Carbon drop out  
**WEIGHTS:** g

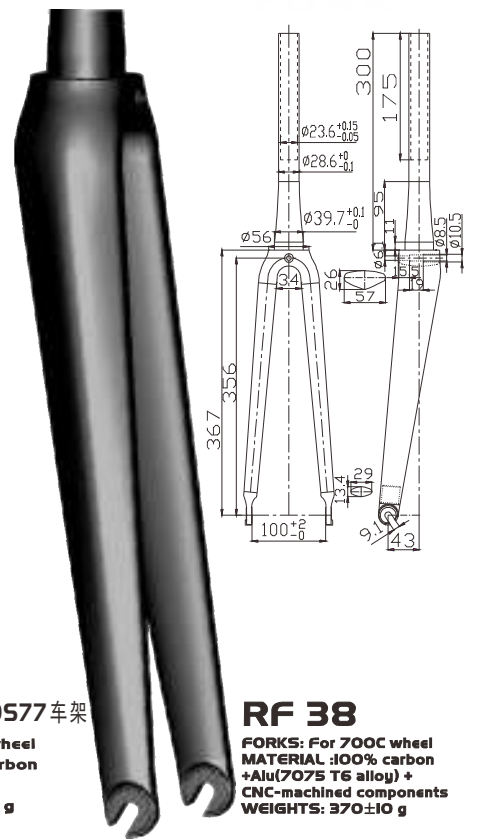

**RF 38**

**FORKS:** For 700C wheel  
**MATERIAL:** 100% carbon  
 +Alu(7075 T6 alloy) +  
 CNC-machined components  
**WEIGHTS:** 370±10 g

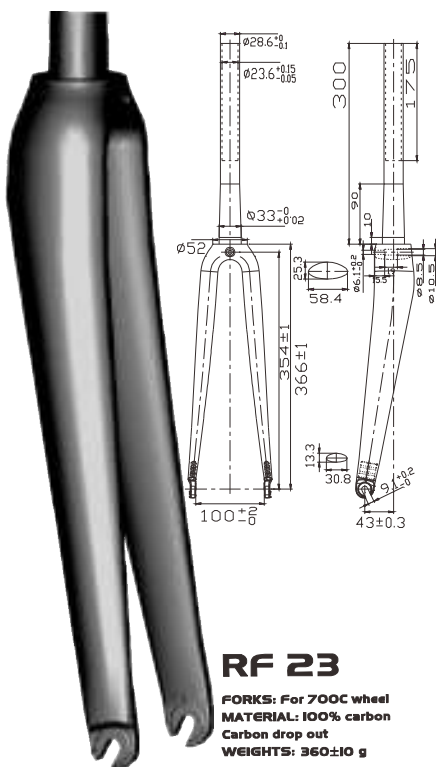

**RF 23**

**FORKS:** For 700C wheel  
**MATERIAL:** 100% carbon  
 Carbon drop out  
**WEIGHTS:** 360±10 g

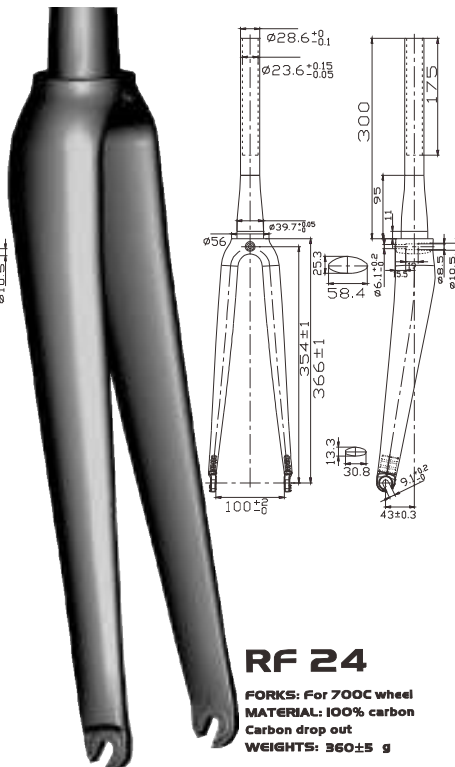

**RF 24**

**FORKS:** For 700C wheel  
**MATERIAL:** 100% carbon  
 Carbon drop out  
**WEIGHTS:** 360±5 g

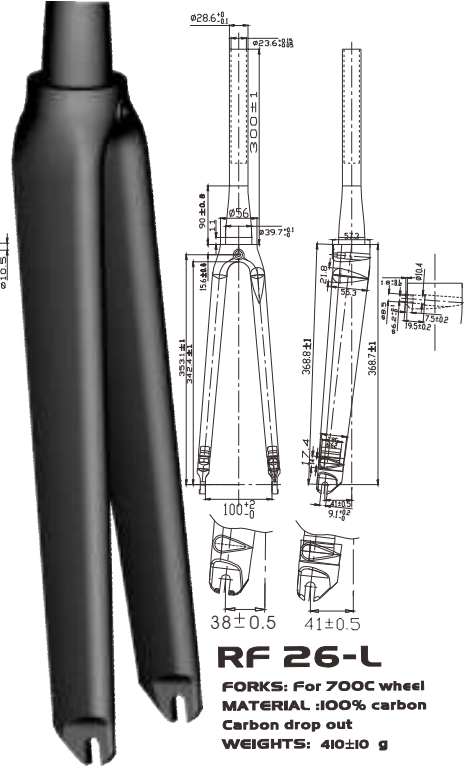

**RF 26-L**

**FORKS:** For 700C wheel  
**MATERIAL:** 100% carbon  
 Carbon drop out  
**WEIGHTS:** 410±10 g

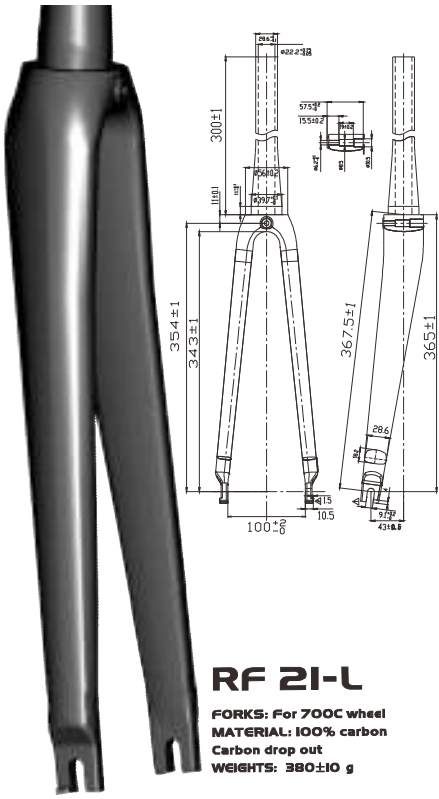

**RF 21-L**

**FORKS:** For 700C wheel  
**MATERIAL:** 100% carbon  
 Carbon drop out  
**WEIGHTS:** 380±10 g

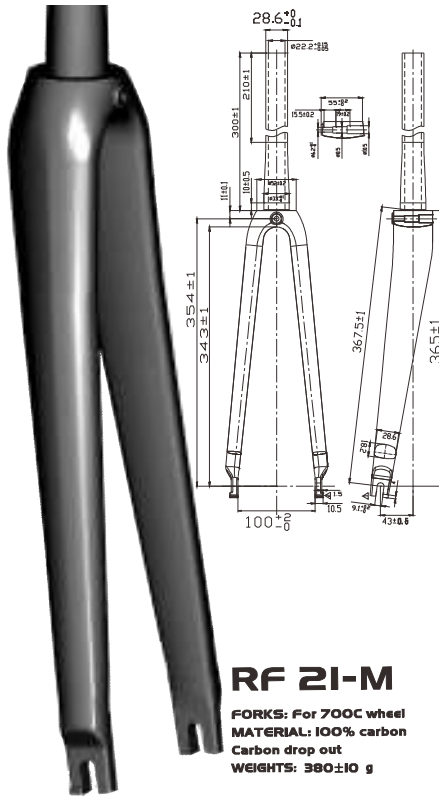

**RF 21-M**

**FORKS:** For 700C wheel  
**MATERIAL:** 100% carbon  
 Carbon drop out  
**WEIGHTS:** 380±10 g

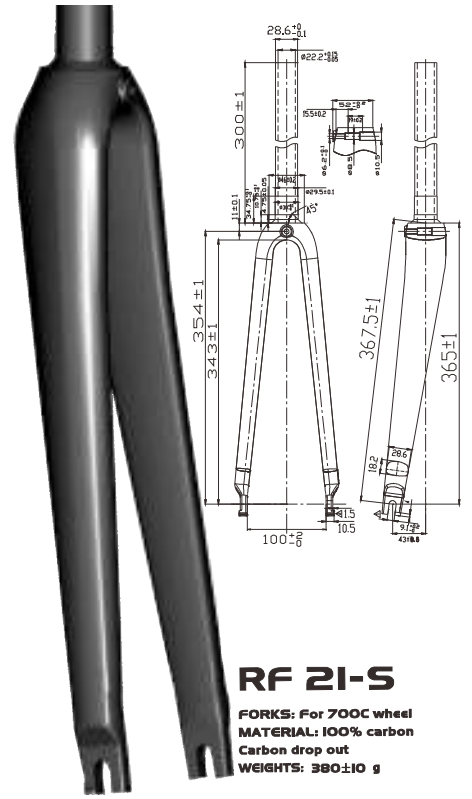

**RF 21-S**

**FORKS:** For 700C wheel  
**MATERIAL:** 100% carbon  
 Carbon drop out  
**WEIGHTS:** 380±10 g

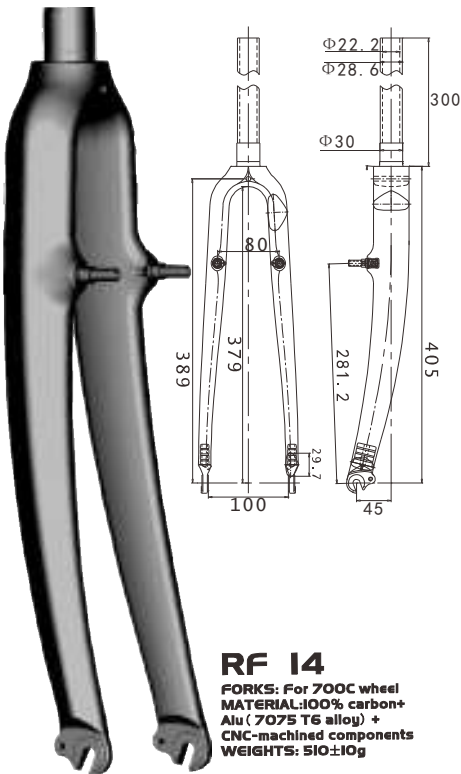

**RF 14**

**FORKS:** For 700C wheel  
**MATERIAL:** 100% carbon +  
 Alu (7075 T6 alloy) +  
 CNC-machined components  
**WEIGHTS:** 510±10g

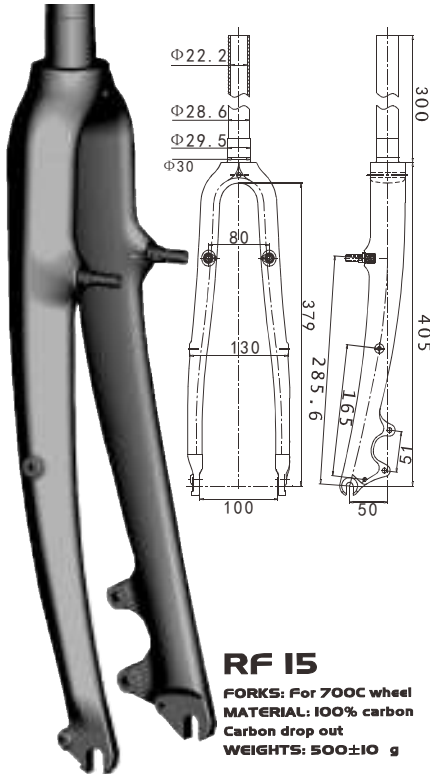

**RF 15**

**FORKS:** For 700C wheel  
**MATERIAL:** 100% carbon  
 Carbon drop out  
**WEIGHTS:** 500±10 g

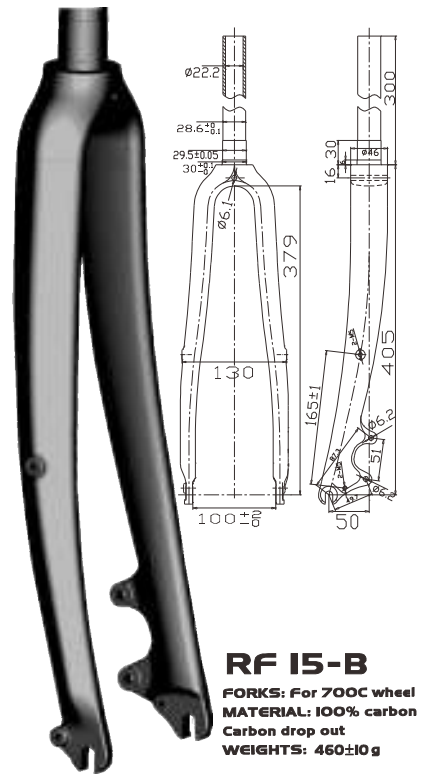

**RF 15-B**

**FORKS:** For 700C wheel  
**MATERIAL:** 100% carbon  
 Carbon drop out  
**WEIGHTS:** 460±10g

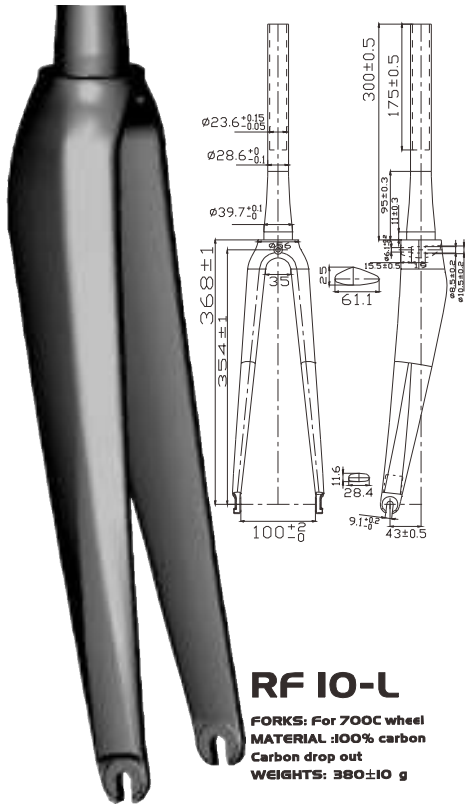

**RF 10-L**

FORKS: For 700C wheel  
 MATERIAL: 100% carbon  
 Carbon drop out  
 WEIGHTS: 380±10 g

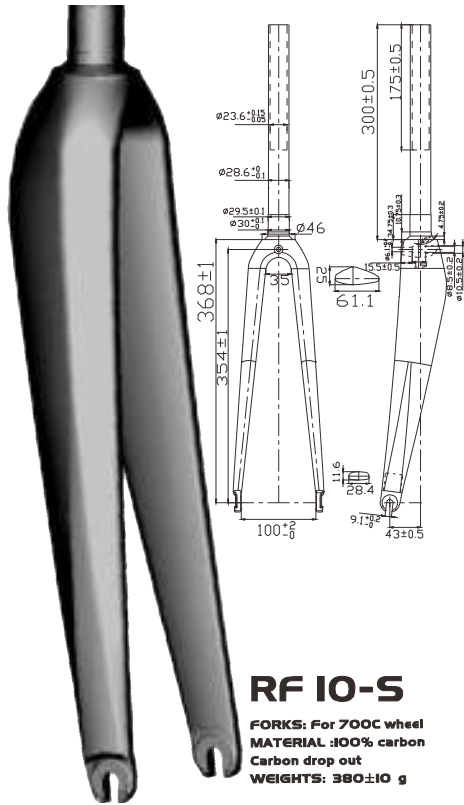

**RF 10-S**

FORKS: For 700C wheel  
 MATERIAL: 100% carbon  
 Carbon drop out  
 WEIGHTS: 380±10 g

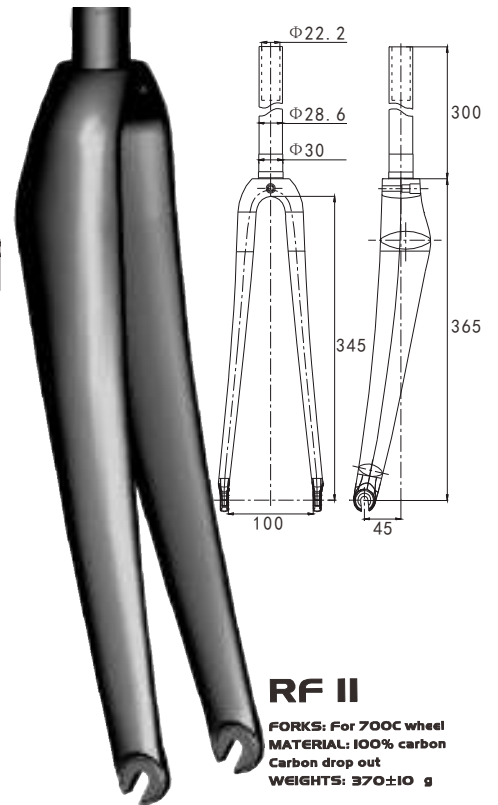

**RF II**

FORKS: For 700C wheel  
 MATERIAL: 100% carbon  
 Carbon drop out  
 WEIGHTS: 370±10 g

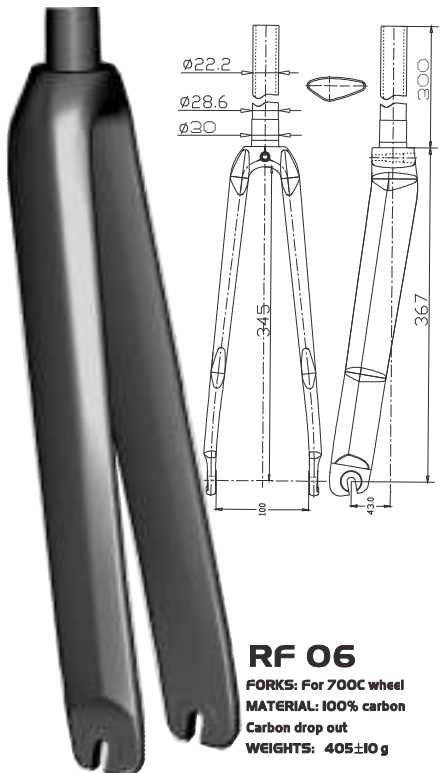

**RF 06**

FORKS: For 700C wheel  
 MATERIAL: 100% carbon  
 Carbon drop out  
 WEIGHTS: 405±10 g

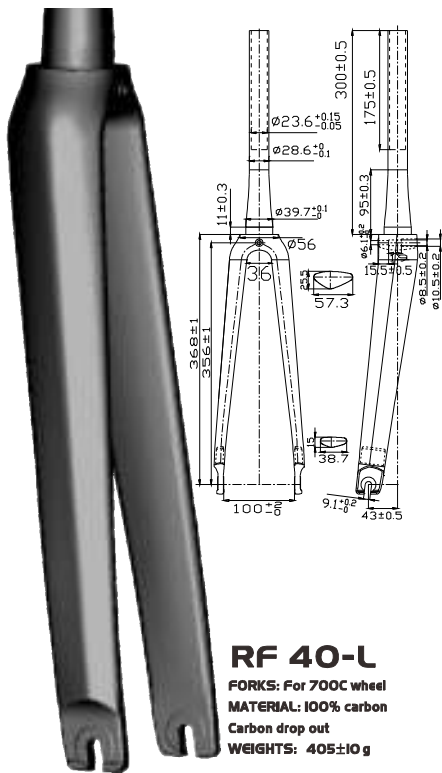

**RF 40-L**

FORKS: For 700C wheel  
 MATERIAL: 100% carbon  
 Carbon drop out  
 WEIGHTS: 405±10 g

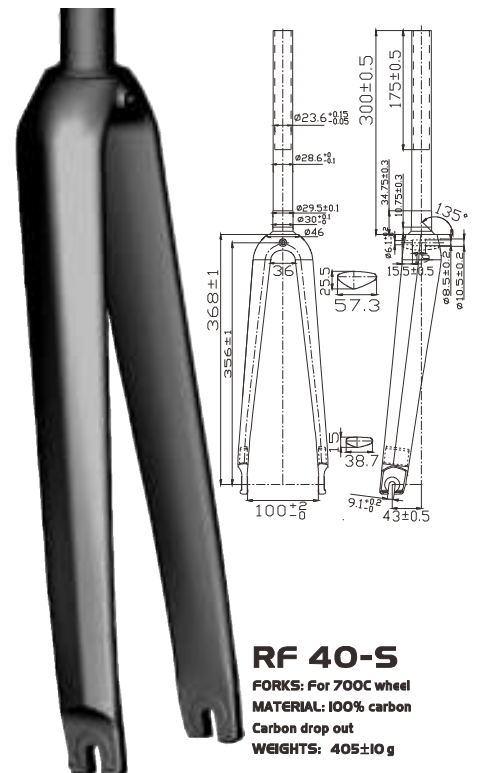

**RF 40-S**

FORKS: For 700C wheel  
 MATERIAL: 100% carbon  
 Carbon drop out  
 WEIGHTS: 405±10 g

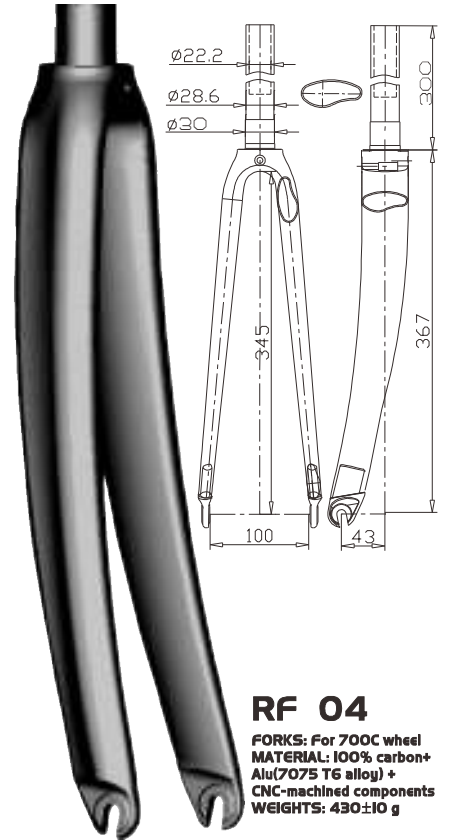
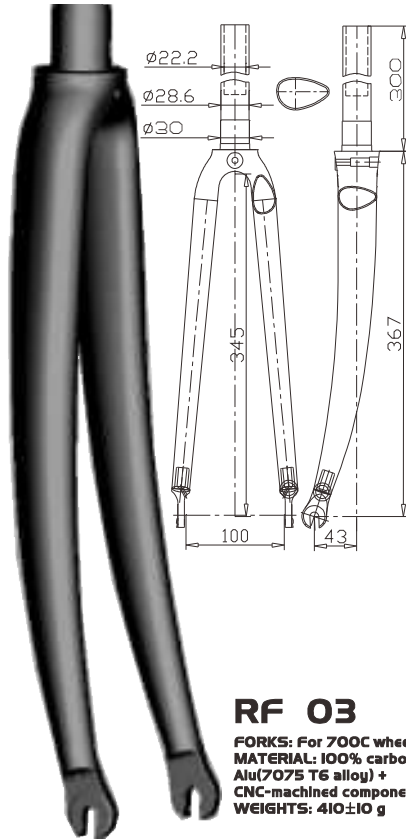
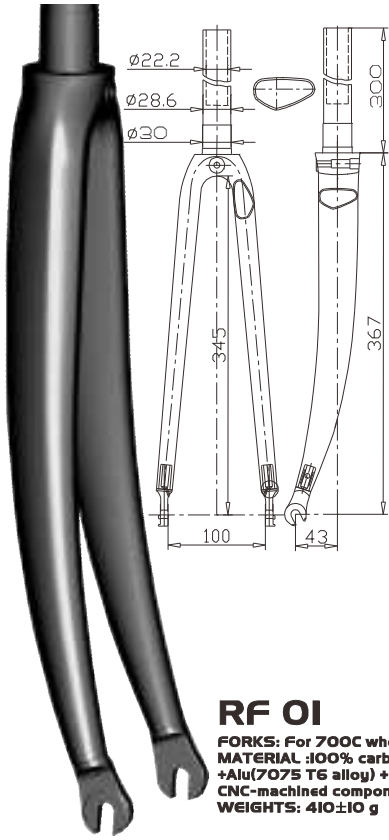

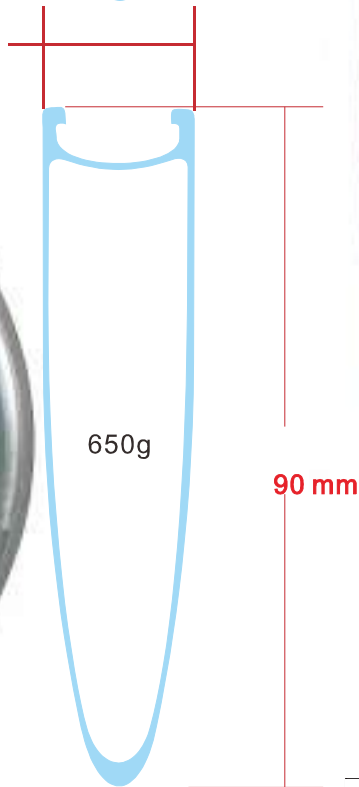
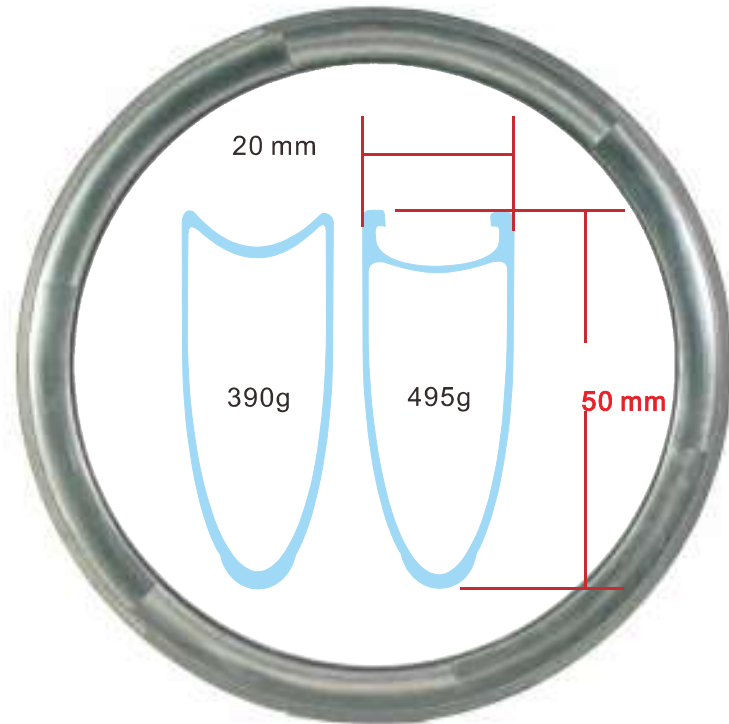
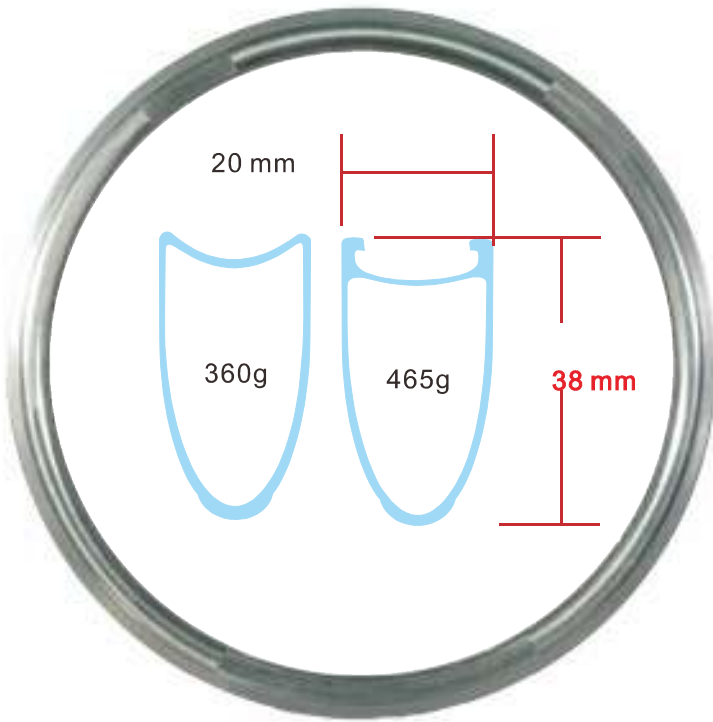

**Bike Test Aachen**  
Institut für Kraftfahrzeugtechnik  
Aachen University of Applied Sciences  
Campus Aachen - Ost  
Cologne University of Applied Sciences  
Campus Aachen - Ost

TECHNISCHE UNIVERSITÄT AACHEN  
Fakultät für Maschinenbau  
Institut für Kraftfahrzeugtechnik  
Campus Aachen - Ost  
Cologne University of Applied Sciences  
Campus Aachen - Ost

SEIUNO PRODUCTS Co., Ltd.  
2021, No. 111, Chung-Ping Road, Hsinchu 300, Taiwan, R.O.C.  
Tel: 886 22814 437, Fax: 886 22812 8188

For the combination: SEIUNO POWER Q8-315-3C brake shoes with RECYCLED carbon fibre rims

**Test-Certificate**

The certificate is valid for the combination: SEIUNO POWER Q8-315-3C brake shoes with RECYCLED carbon fibre rims

TESTING ACCORDING TO: DIN EN 14786 (brake shoes) / DIN EN 14786 (brake shoes) / RECYCLED carbon fibre rims

DIN EN 14786 (brake shoes) / DIN EN 14786 (brake shoes) / RECYCLED carbon fibre rims

DIN EN 14786 (brake shoes) / DIN EN 14786 (brake shoes) / RECYCLED carbon fibre rims

DIN EN 14786 (brake shoes) / DIN EN 14786 (brake shoes) / RECYCLED carbon fibre rims

DIN EN 14786 (brake shoes) / DIN EN 14786 (brake shoes) / RECYCLED carbon fibre rims

DIN EN 14786 (brake shoes) / DIN EN 14786 (brake shoes) / RECYCLED carbon fibre rims

DIN EN 14786 (brake shoes) / DIN EN 14786 (brake shoes) / RECYCLED carbon fibre rims

DIN EN 14786 (brake shoes) / DIN EN 14786 (brake shoes) / RECYCLED carbon fibre rims

DIN EN 14786 (brake shoes) / DIN EN 14786 (brake shoes) / RECYCLED carbon fibre rims

DIN EN 14786 (brake shoes) / DIN EN 14786 (brake shoes) / RECYCLED carbon fibre rims

DIN EN 14786 (brake shoes) / DIN EN 14786 (brake shoes) / RECYCLED carbon fibre rims

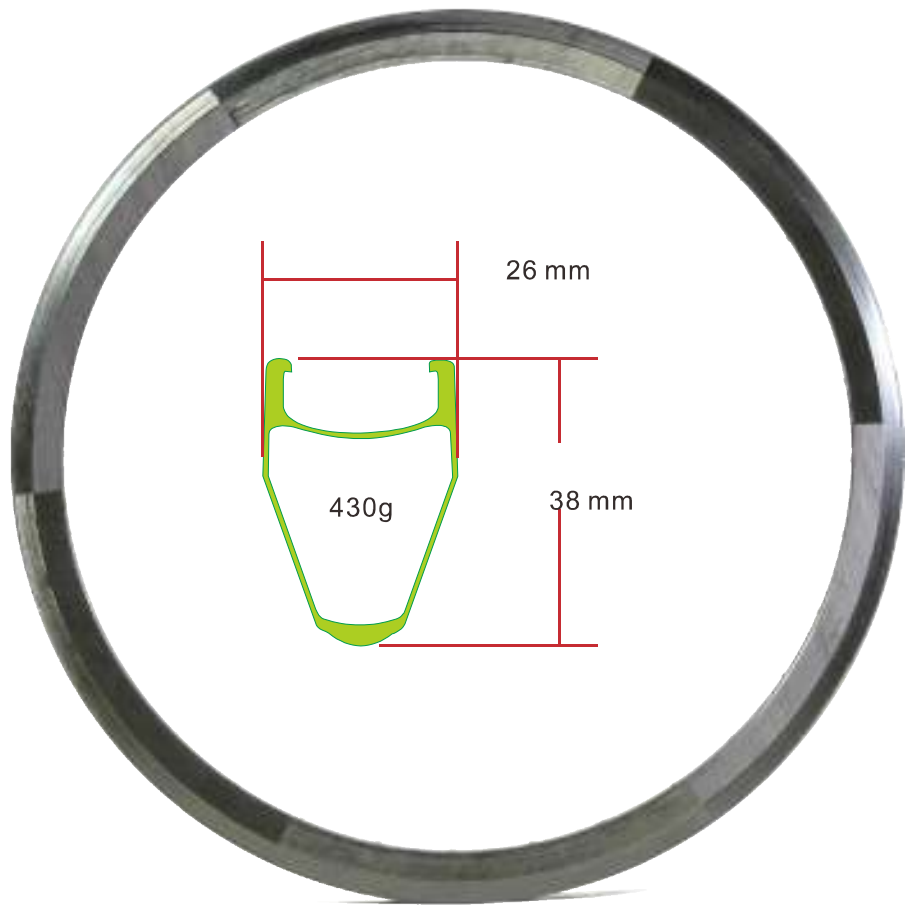



### MHB-300

DIAMETER:  $\varnothing 31.8$  mm  
MATERIAL: 100%GRA+3K  
WEIGHT: 135 $\pm$ 5g



### MHB-210

DIAMETER:  $\varnothing 31.8$  mm  
MATERIAL: 100%GRA+3K  
WEIGHT: 154 $\pm$ 5g(630mm)  
157 $\pm$ 5g(680mm)



### MHB-800

DIAMETER:  $\varnothing 31.8$  mm  
MATERIAL: 100%GRA+3K  
WEIGHT: 158 $\pm$ 5g(630mm)  
165 $\pm$ 5g(680mm)



### TA-0810

DIAMETER:  $\varnothing 31.8$  mm  
MATERIAL: 100%GRA+3K  
WEIGHT: 158 $\pm$ 5g(630mm)  
165 $\pm$ 5g(680mm)



### HBL-90

MATERIAL: 100%GRA+3K  
WEIGHT: 149 $\pm$ 5g

### HBL-100

MATERIAL: 100%GRA+3K  
WEIGHT:

### HBL-110

MATERIAL: 100%GRA+3K  
WEIGHT:

### HBL-120

MATERIAL: 100%GRA+3K  
WEIGHT: 167 $\pm$ 5g



### RHB-200

DIAMETER:  $\varnothing 31.8$  mm  
MATERIAL: 100%GRA+3K  
WEIGHT: 210 $\pm$ 5g



### HBL-01

DIAMETER:  $\varnothing 31.8$  mm  
MATERIAL: 100%GRA+3K  
WEIGHT: 210 $\pm$ 5g



Patent

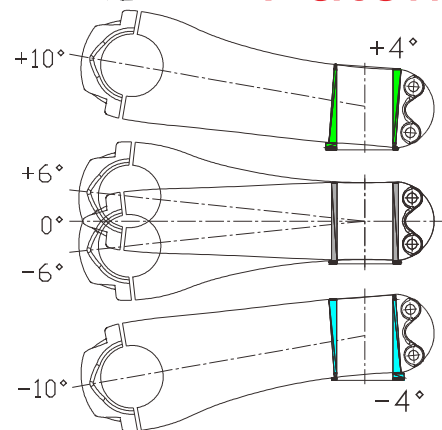

### HBA-120D

MATERIAL: 100%GRA+3K  
WEIGHT: 184 $\pm$ 5g

# 15 HEADSET CAPS

Patent  
PAT.

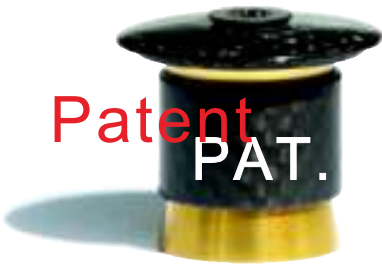

**SP-01-C**

Size: 19.0-22.2mm  
20.0-24.0mm  
24.0-25.4mm  
Weight: 12g



**SP-01-A**

Size: 19.0-22.2mm  
20.0-24.0mm  
24.0-25.4mm  
Weight: 15g



**SP-02**

Size: 1"  
1" 1/8  
Weight: 19g

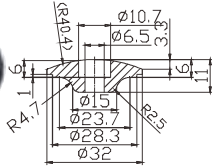

**CAP  
CP 01**

DIAMETER: 1-1/8"  
MATERIAL: 100% Carbon  
WEIGHT: 6g

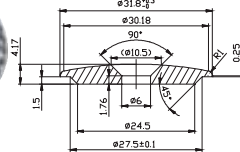

**CAP  
CP 02**

DIAMETER: 1-1/8"  
MATERIAL: 100% Carbon  
WEIGHT: 3g

## HEADSET

**HC-01-C/A**

HIGHT SIZE: 5mm  
20mm  
25mm

BEARING SIZE: UP

- 36X36X41
- 36X45X41
- 45X45X41.8
- 45X45X41

DOWN

- 45X45X47
- 36X45X51.8



MATERIAL: Carbon / Aluminum





## SPACER

### SP 01

DIAMETER: 1-1/8"

MATERIAL: Graphite

HEIGHT: 4mm 5mm 8mm  
10mm 12mm 15mm  
20mm 25mm

5mm  
20mm  
25mm

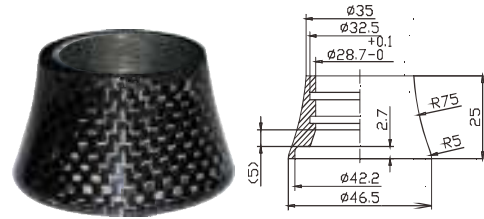

## CONICAL COVER

### CC 25

DIAMETER: 1-1/8"

MATERIAL: 100% Carbon

WEIGHT: 16 ± 3 g

# SEAT CLAMP



**SEAT CLAMP - 01**  
Material: CNC 7075 T6 Aluminum  
Weight: 12 g



**SEAT CLAMP - 04**  
Material: CNC 6061 T6 Aluminum  
Weight: 23 g



**SEAT CLAMP - 03**  
Material: CNC 6061 T6 Aluminum  
Weight: 30 g



| DATA        |       |        |
|-------------|-------|--------|
| DOUBLE Ø mm | TEETH | HOLES  |
| Ø 135       | 53    | 5      |
| Ø 135       | 39    | 5      |
| Ø 130       | 53    | 5      |
| Ø 130       | 39    | 5      |
| Ø 110       | 50    | 5      |
| Ø 110       | 34    | 5      |
| Ø 104       | 44    | 4 or 5 |
| Ø 104       | 32    | 4 or 5 |
| Ø 64        | 22    | 4 or 5 |

# 17 BOTTLE CAGE PRO FESSIONAL

Material: Carbon / Glass fiber  
Weight: 22~36g

**WG 08**  
MATERIAL: 100% Carbon  
WEIGHT: 21-24g



**WG 05**  
MATERIAL: 100% Carbon  
WEIGHT: 20-23g



**WG 04**  
MATERIAL: 100% Carbon  
WEIGHT: 21-24g



**WG 03**  
MATERIAL: 100% Carbon  
WEIGHT: 19-22g



**W-05**



**W-06**



**W-08**



**WG 14**  
MATERIAL: 100% Carbon  
WEIGHT: 19-21g



**WG 06**  
MATERIAL: 100% Carbon  
WEIGHT: 20-23g



**W-22**



**WG 22**  
MATERIAL: 100% Carbon  
WEIGHT: 22-24g



**WG 19**  
MATERIAL: 100% Carbon  
WEIGHT: 18-20g



**W-26**

**WG 33**  
MATERIAL: 100% Carbon  
WEIGHT: 19-21g



**WG 07 (Long)**  
MATERIAL: 100% Carbon  
WEIGHT: 21-24g



**SCREW**

Material: 7075 T6 aluminum  
Weight: 1g

**WG 26**  
MATERIAL: 100% Carbon  
WEIGHT: 19-21g



**WG 31**  
MATERIAL: 100% Carbon  
WEIGHT: 19-21g



**WG 24**  
MATERIAL: 100% Carbon  
WEIGHT: 21-23g



**WG 25**  
MATERIAL: 100% Carbon  
WEIGHT: 18-21g



**WG 32**  
MATERIAL: 100% Carbon  
WEIGHT: 19-21g





Carbon CNC

FEATHER LIGHT 



## PARTICLE TECHNIQUE

### BRAKE PAD-ROAD FOR CARBON RIMS

System: Campagnolo   
 Shimano  
**ROAD**



### Disc BRAKE PAD FOR DISC

SHIMANO  
XTR-XT-LX



MAGURA



### CERAMIC BRAKE PAD-ROAD

System: Campagnolo   
 Shimano   
**ROAD**



SHIMANO  
DEORE



HAYES



### CERAMIC BRAKE PAD-V

System: Shimano   
**MTB** 



SHIMANO  
XT-OLD MODEL





PAT.

## REPLACEABLE DROPOUT

Material: CNC Carbon  
Weight: 8.8 g



## BRAZE ON

Material: CNC Carbon  
Weight: 3 g



## FRONT-DERAILLEUR CLAMP

Size: 34.9mm  
Material: 6061 T6 Aluminum  
Weight: 33 g  
Size: 34.9 / 31.8 mm



## CHAIN FALL-PROTECTOR CLAMP

Material: Nylon  
Weight: 12 g  
Size: 34.9 / 31.8 / 28.6 mm

Size: 1" - 1" 1/8"  
Height: 4mm 2g  
5mm 3g  
8mm 3g  
10mm 4g  
12mm 5g  
15mm 6g  
20mm 8g



## CARBON SPACER



PAT.

**CARBON  
JACKY WIELL**  
Material: CNC Carbon  
Weight: 18 g

**FEATHER LIGHT**



## STICKER



STICKER CABLE-01  
(CRYSTAL)



STICKER CABLE-01  
(CARBON VERSION)



STICKER CHAIN-01 (CARBON VERSION)



STICKER CHAIN-01 (CRYSTAL)



STICKER CHAIN-02 (CARBON VERSION)



TAPE-01



BAR PLUGS





**DERAILLEUR**  
**NEW 1.2MM**  
ROAD MTB



**BRAKE ROAD**  
ROAD

P  
B  
O



**BRAKE MTB**  
MTB

F  
I  
B  
E  
R



Zero Gravity 6mm



Campagnolo 5mm



Shimano 6mm

**SHOULDER BOLT CLASP**

For brake cable ROAD MTB

Weight: 2g

Compatible: 5mm Campagnolo

6mm Shimano

Zero Gravity

FEATHER LIGHT 

## REPAIR STAND

MATERIAL: Carbon

WEIGHT: 1.5 kg

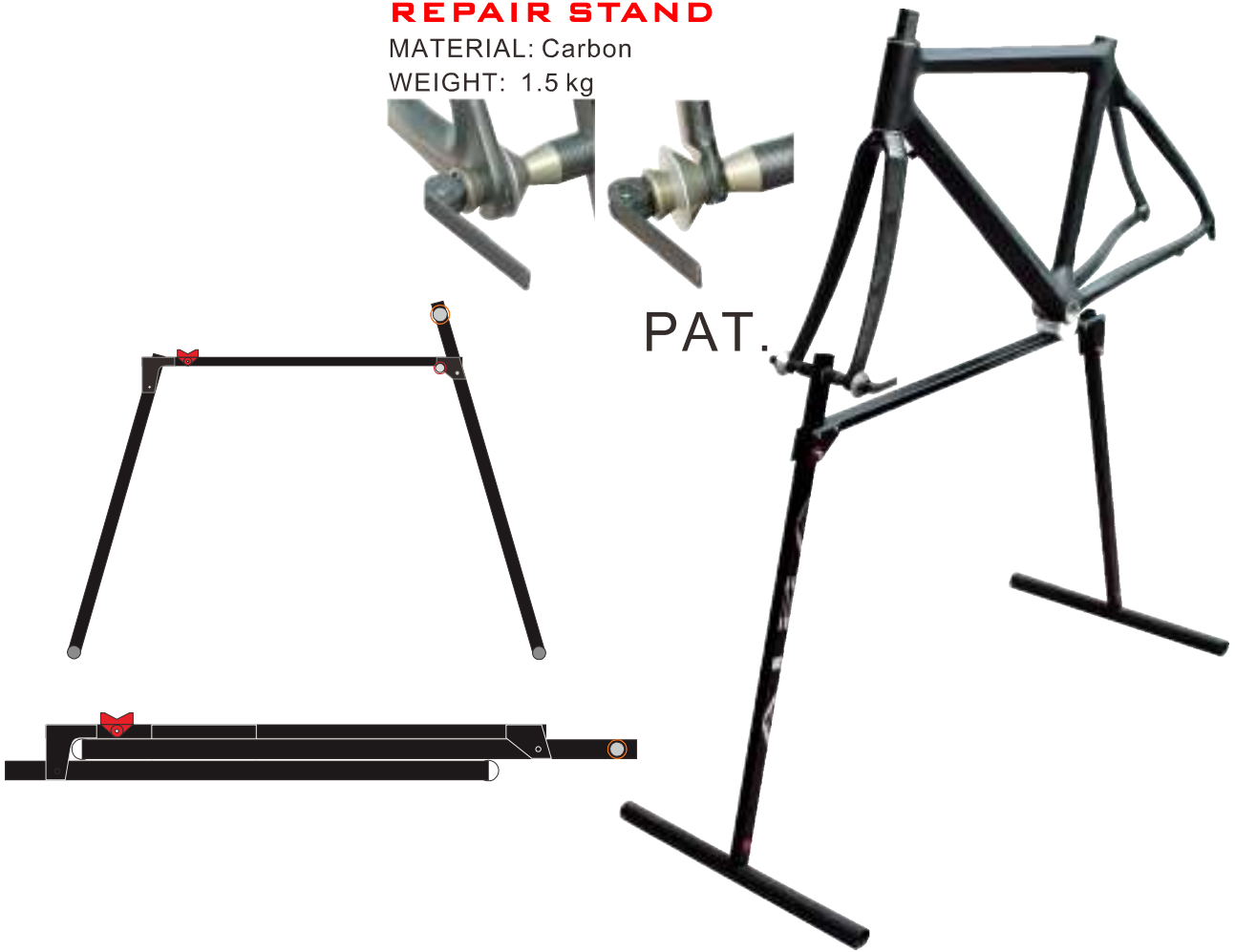

## ROLLER BAR

Size: 100mm

WEIGHT: 800g



## ROLLER TRAINER

Size: 100mm

WEIGHT: 3.8kg

**TOL-01**

Material: Carbon / Ti / Steel

Weight: 20g



Model: 1 2 3 4 5

**WITH TI SCREW** ▶

**18K GOLD**  
**FEATHER LIGHT**



**SCREW**



5x15 mm



4x20 mm

Material: 7075 T6 aluminum

Weight: 1g

**Ti Derailleur Cable Adjust Device**



**DISPLAY STAND**

Material: Carbon tube  
6061 T6 Aluminum lock

**FEATHER LIGHT**







**CARBON WALLET**



**KEY CHAIN**  
SHOE HORN



**BUSINESS  
CARD WALLET**

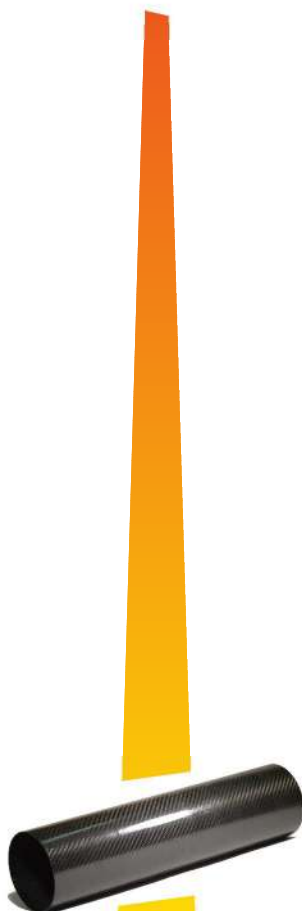
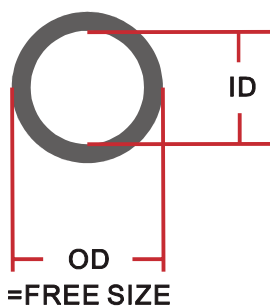

| Inside diameter (mm) ID | Length (mm) L | Specifiction             | Inside diameter (mm) ID | Length (mm) L | Specifiction                |
|-------------------------|---------------|--------------------------|-------------------------|---------------|-----------------------------|
| 2.00                    | 450           |                          | 24.00                   | 1310          |                             |
| 3.00                    | 1300          |                          | 24.40                   |               | seatpost                    |
| 3.10                    | 550           |                          | 24.58                   | 1330          |                             |
| 3.20                    |               | frame top tube           | 24.65                   | 1200          |                             |
| 3.60                    |               | frame top tube           | 25.00                   | 1250          |                             |
| 4.00                    |               | frame top tube           | 25.20                   |               | seat tube                   |
| 4.30                    |               | frame top tube           | 25.40                   | 1320          |                             |
| 4.60                    |               | frame top tube           | 25.60                   | 920           |                             |
| 5.00                    |               | frame top tube           | 25.60                   |               | 1" spacers                  |
| 5.4x14.20               | 1730          |                          | 25.60                   | 1250          |                             |
| 9x8                     |               | seat stay                | 25.60                   | 1280          |                             |
| 11.00                   | 1200          |                          | 25.78                   | 1230          |                             |
| 11.75                   | 1270          |                          | 25.80                   |               | seatpost                    |
| 12.00                   | 1050          |                          | 26.55                   | 1200          |                             |
| 12x8                    |               | seat stay                | 26.55                   | 1260          |                             |
| 12.47                   | 1250          |                          | 26.97                   | 1260          |                             |
| 12.95                   | 1230          |                          | 27.00                   |               | seatpost                    |
| 12.95                   | 1300          |                          | 27.17                   | 1240          |                             |
| 13.40                   | 1150          |                          | 28.00                   |               | down tube or 1" 1/8 spacers |
| 14.00                   | 1200          |                          | 28.00                   |               | head tube                   |
| 14.35x                  | 1130          |                          | 28.15                   | 1260          |                             |
| 14.95                   | 1270          |                          | 28.30                   |               | top tube                    |
| 14.80                   | 1300          |                          | 28.60                   | 900           |                             |
| 15.00                   | 1150          |                          | 28.60                   |               | Cftube                      |
| 15.75                   | 1350          |                          | 28.60                   | 1050          |                             |
| 16.00                   |               | frame tube               | 28.6x27.3               |               | frame tube                  |
| 16.35                   | 1400          |                          | 28.75x27.25             | 1000          |                             |
| 16.98                   | 1300          |                          | 28.80                   | 900           |                             |
| 17.80                   | 1330          |                          | 28.80                   |               | 1" 1/8 spacers              |
| 19.00                   |               | seatpost or barend       | 28.90                   |               | peddles                     |
| 19.00                   | 1280          |                          | 30.60                   | 1050          |                             |
| 19.21                   | 1000          |                          | 31.48                   | 1200          |                             |
| 20.00                   |               | 1" stem                  | 31.60                   | 960           |                             |
| 20.15                   | 1200          |                          | 31.70                   |               | CF tube                     |
| 20.60                   |               | seatpost or barend       | 31.75x25.40             | 620           |                             |
| 20.67                   | 1350          |                          | 32.00                   | 1000          |                             |
| 20.77                   | 1480          |                          | 32.00                   |               |                             |
| 20.80x                  | 510           |                          | 32.30x25.90             | 580           |                             |
| 20.95                   | 1320          |                          | 34.85                   | 1100          |                             |
| 21.00                   |               | seatpost                 | 34.88                   | 1100          |                             |
| 21.00                   | 1200          |                          | 34.90                   |               | CF tube                     |
| 21.78                   | 1230          |                          | 37.05                   | 850           |                             |
| 21.80                   |               | seatpost                 | 38.00                   |               | CF tube                     |
| 22.00                   | 1300          |                          | 38.17                   | 1050          |                             |
| 22.15                   | 1150          |                          | 38.30                   |               | down tube                   |
| 22.15                   | 1420          |                          | 38.95                   | 910           |                             |
| 23.25                   | 1220          |                          | 39.90                   | 1000          |                             |
| 22.60                   |               | seatpost                 | 42.90                   | 1050          |                             |
| 22.80                   |               | seatpost                 | 45~34.7                 |               | 48X37.7X1.5 CF tube         |
| 23.00                   |               | seat tube or 1 1/8" stem | 47.60                   |               | CF tube                     |
| 23.60                   |               | 1 1/8" stem              | 70x70/30x1180           |               | R                           |
| 24.00                   |               | seatpost                 | 109.00                  |               | motorcycle pipe             |
| 24.00                   | 1020          |                          |                         |               |                             |

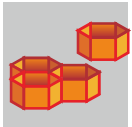

HONEYCOMB CORE



SPECIAL MATERIAL AND EQUIPMENT  
TOOL APPLICATION



RTM / VRTM (Resin Transfer Moulding)



DESIGN/ IDEA/ MATERIAL TECHNOLOGY  
FROM SOAR DESIGN TEAM



HIGH TEMPERATURE

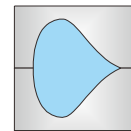

HOSE BLOW METHOD



HIGH PRESSURE & METAL WITH  
LOT PIECES



CARBON CNC

**CARBON R.T.M.  
NEW FACTORY**

**BICYCLE & RACKET FACTORY**



**CARBON CNC  
MACHINING**



**MATERIAL & TOOL TECHNOLOGY**

材料工具代理 & 技術應用服務

**HUNTSMAN**  
Enriching lives through innovation  
愛年達Araidite 愛年固Aradur  
專業聯合濟系統 專業樹脂模具系統  
環氧樹脂系統

**BORON FIBER**  
全系列硼纖維  
**SPECIALTY MATERIALS, INC.**

**HONEY WAX**  
PRESSURE BOND RELEASE PASTE  
高性能表現脫模蠟  
**SPECIALTY PRODUCTS**  
www.spacialtyproductsco.com

**KLOBER**  
KLOBER  
特殊高潔度火油油  
乾式薄燒劑 / 潤滑油 / 阻尼  
/ 兩色保護 / 油隔 / 噴層阻劑

**AIRTECH**  
R.T.M. 真空成型材料產品

**HV**  
Hollingsworth & Vose  
特殊纖維不織布纖維類品

**sigmatex**  
material innovation

**XAO**  
蜂巢版

**Barrday**  
防彈布料  
碳纖維布料  
熱塑性布料  
**WORLD CLASS QUALITY**

**HUK DOPAG**  
DOPAG  
混料射出機  
點膠機

**KAI PROFESSION SCISSORS**  
複合材料作業專用剪刀

**AKZO NOBEL**  
AEROSPACE COATINGS  
飛行塗料專家

**Cytec**  
ENGINEERED MATERIALS  
高科技專業複合材料

**HITCO**  
耐高溫 耐火  
特殊複材

**RAW MATERIAL**



3D Carbon Wovens



**FASHION**

- 01
- 02
- 03

**UD WOVEN**

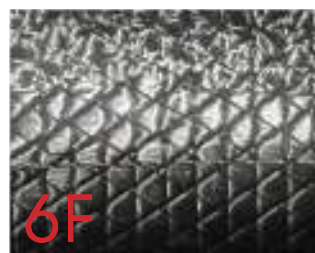
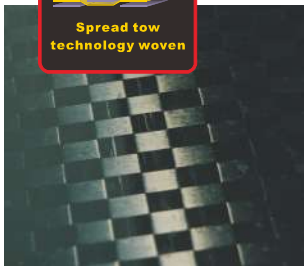





ASIA SEIKO COMPOSITE MATERIAL Co.,Ltd

OEM ODM OBM

COMPOSITE MATERIAL PRODUCTS

# ASIA

SEIKO COMPOSITE MATERIAL  
ASIA SEIKO COMPOSITE MATERIAL Co.,Ltd

OEM ODM OBM



BICYCLE



AERO SPACE



LIGHT LIFE



AUTOMOTO



SALES AGENT



MATERIAL & TOOL

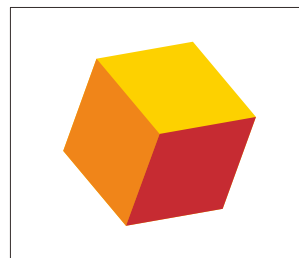

ABOUT US



NEWS

GOLF

ASIA SEIKO COMPOSITE MATERIAL

BIKE

碳纖維加工

CARBON TUBES

真空製程

CNC CARBON

TENNIS

RTM

炭素纖維及びその関連製品

COMPOSITE MATERIAL

MOTO AUTO

SPORTS

羽球拍

ASIA SEIKO COMPOSITE MATERIAL

## COMPOSITE MATERIAL PRODUCTS

27, Shen Lih Rd. Tantz 427 Taichung County, TAIWAN

台灣 台中縣 427 潭子鄉 勝利路 27 號

TEL: +886-4-2533-8663

FAX: +886-4-2533-0985



s1@asiaseiko.com



kype: ASIASEIKO.S1